

REVISIONS					
ZONE	REV	ECN	DESCRIPTION	DATE	APPD
-	A	RCG30810	ORIGINAL RELEASE	2010AUG19	DBM

NOTES:

- MINIMUM CLEARANCE OF 36 INCHES FROM OPPOSING SURFACES IS TO BE MAINTAINED ON ALL SIDES AND OVERHEAD DURING OPERATION.
- INCH AND METRIC DIMENSIONING IN THE FIELD OF THE DRAWING ARE COMBINED BY PLACING THE METRIC DIMENSION BELOW THE INCH DIMENSION.  
E.G. INCH 10.5  
METRIC [267]

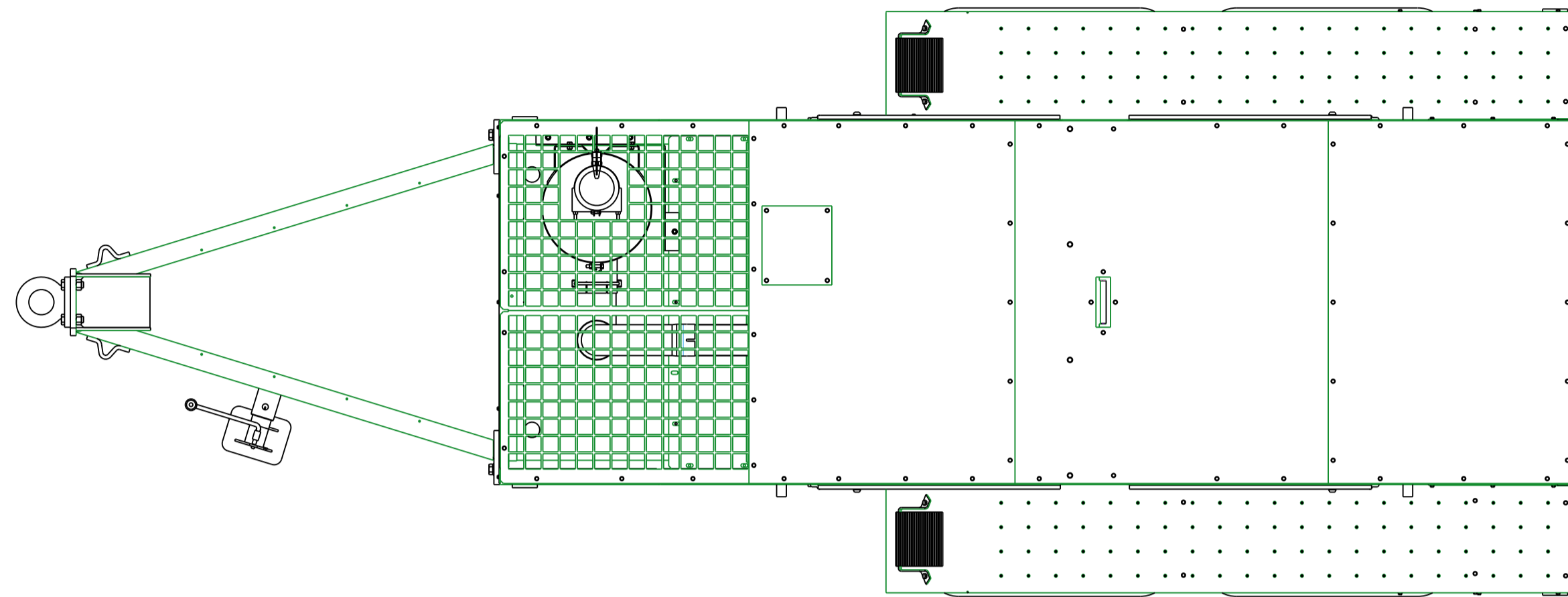

**VIEW B**  
SEE SHEET 3 FOR ENLARGED VIEW

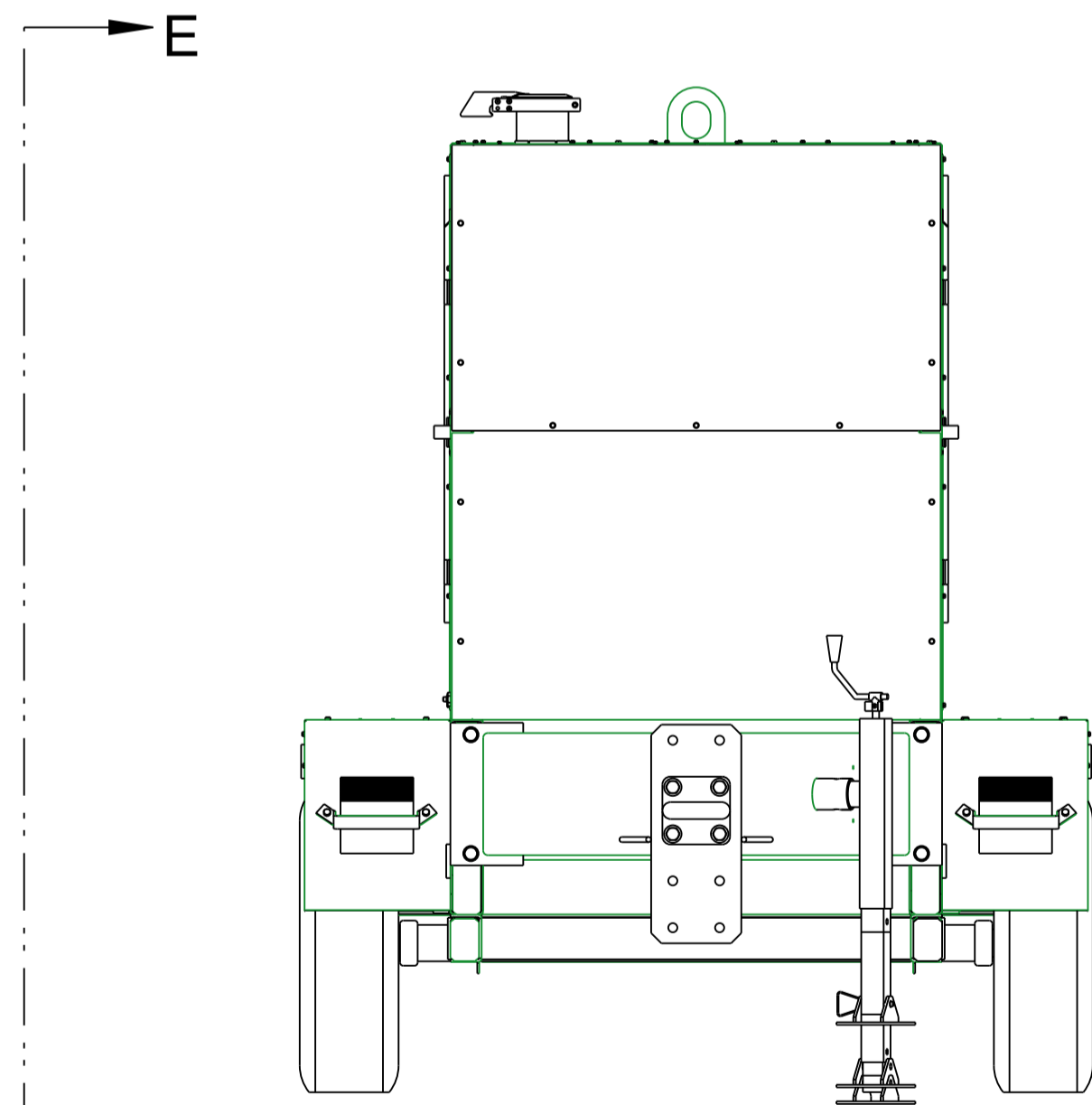

**VIEW C**  
SEE SHEET 4 FOR ENLARGED VIEW

5  
A5

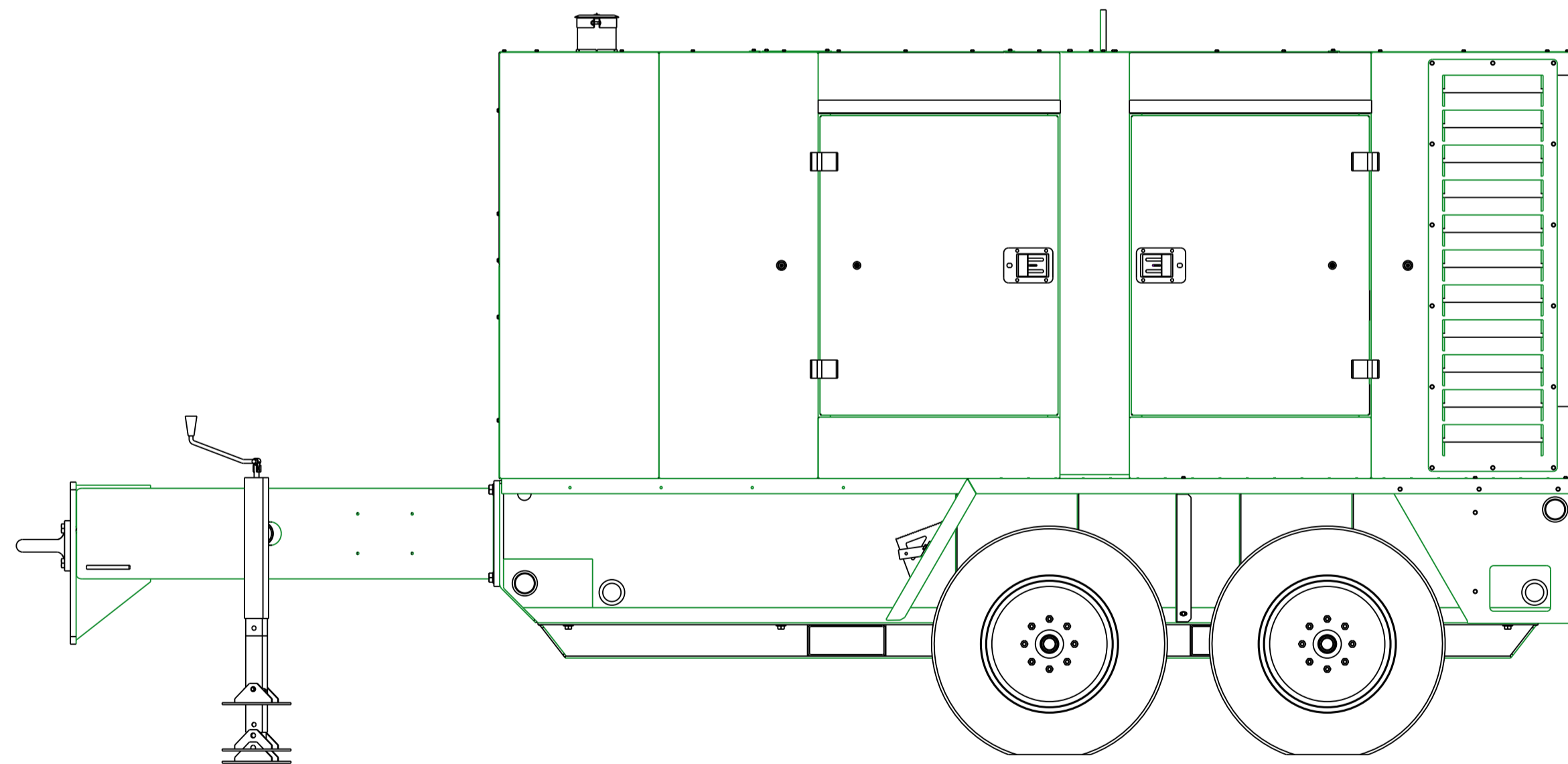

**VIEW A**  
SEE SHEET 2 FOR ENLARGED VIEW

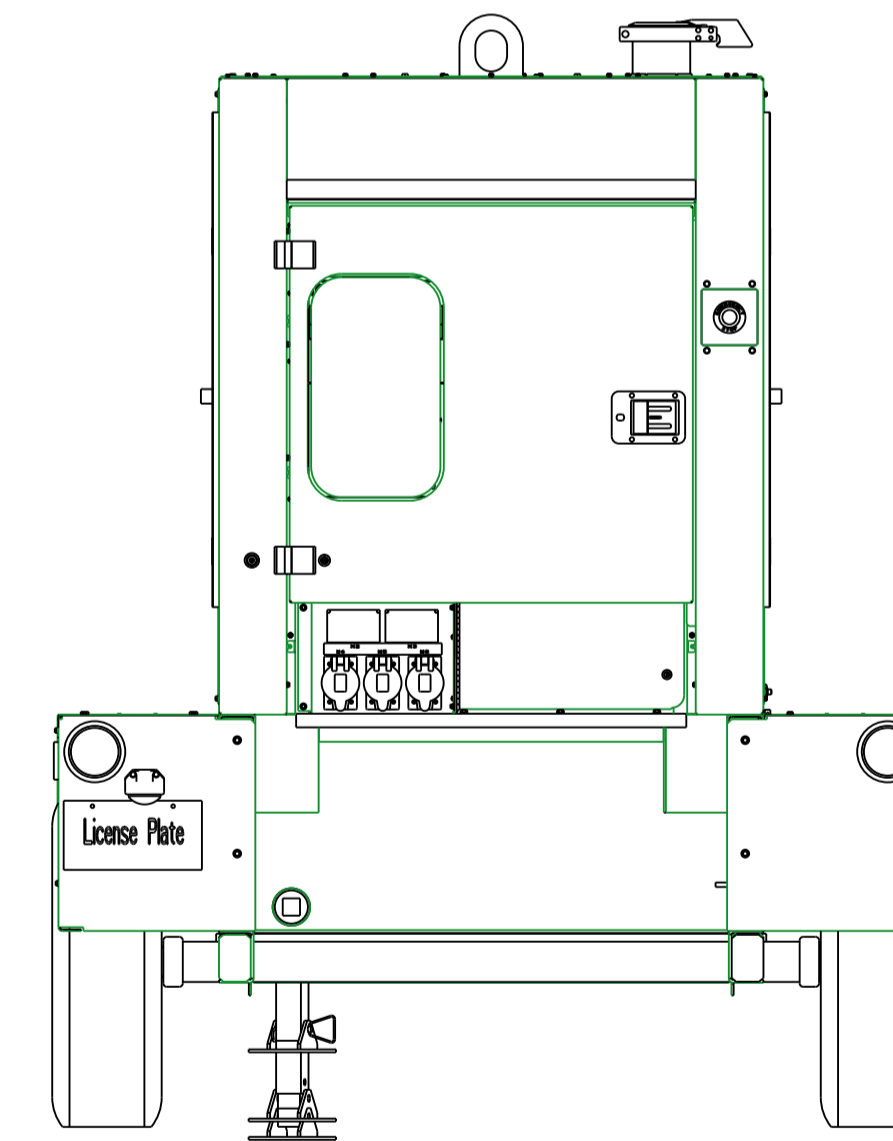

**VIEW D**  
SEE SHEET 4 FOR ENLARGED VIEW

<b>TOLERANCES</b>  UNLESS OTHERWISE SPECIFIED, TOLERANCES ON DIMENSIONS ARE AS SPECIFIED ON DRAWING 36865731  UNLESS OTHERWISE SPECIFIED, ALL DIMENSIONS ARE IN MILLIMETERS. <small>Doosan Infracore Portable Power</small>	<b>PROPRIETARY NOTICE</b>  THIS DRAWING CONTAINS CONFIDENTIAL AND TRADE SECRET INFORMATION, IS THE PROPERTY OF DOOSAN INFRACORE AND IS GIVEN TO THE RECEIVER IN CONFIDENCE. THE RECEIVER BY RECEPTION AND RETENTION OF THE DRAWING ACCEPTS THE DRAWING IN CONFIDENCE AND AGREES THAT, EXCEPT AS AUTHORIZED IN WRITING BY DOOSAN INFRACORE IT WILL (1) NOT USE THE DRAWING COPY THEREOF OR THE CONFIDENTIAL OR TRADE SECRET OR ANY INFORMATION THEREIN; (2) NOT COPY THE DRAWING; (3) NOT DISCLOSE TO OTHERS EITHER THE DRAWING OR THE CONFIDENTIAL OR TRADE SECRET INFORMATION THEREIN; AND (4) UPON COMPLETION OF THE NEED TO RETAIN THE DRAWING, OR UPON DEMAND, RETURN THE DRAWING, ALL COPIES THEREOF, AND ALL MATERIAL COPIED THEREFROM.	WARNING: THE EXPORT OR REEXPORT OF THIS DRAWING OR A PRODUCT PRODUCED BY THIS DRAWING IS SUBJECT TO U.S. EXPORT ADMINISTRATION REGULATIONS AND OTHER APPLICABLE GOVERNMENT RESTRICTIONS OR REGULATIONS.  COPYRIGHT © 2010 DOOSAN INFRACORE ALL RIGHTS RESERVED	THIRD ANGLE PROJECTION DO NOT SCALE DRAWING DRAWING CONFORMS TO ASME Y14.5M - 1994 CAD GENERATED DRAWING. NO MANUAL REVISIONS ALLOWED UNLESS OTHERWISE SPECIFIED: - REMOVE ALL BURRS AND SHARP CORNERS - WELD SYMBOLS TO BE IN ACCORDANCE WITH ANSI/AWS A2.4		
			TITLE <b>GENERAL ARRANGEMENT</b>	SIZE: <b>A1</b> SCALE: 0.03	ESTIMATED WEIGHT (KG UNLESS OTHERWISE SPECIFIED): - UNIT: G185/240

8 7 6 5 4 3 2 1

D  
C  
B  
A

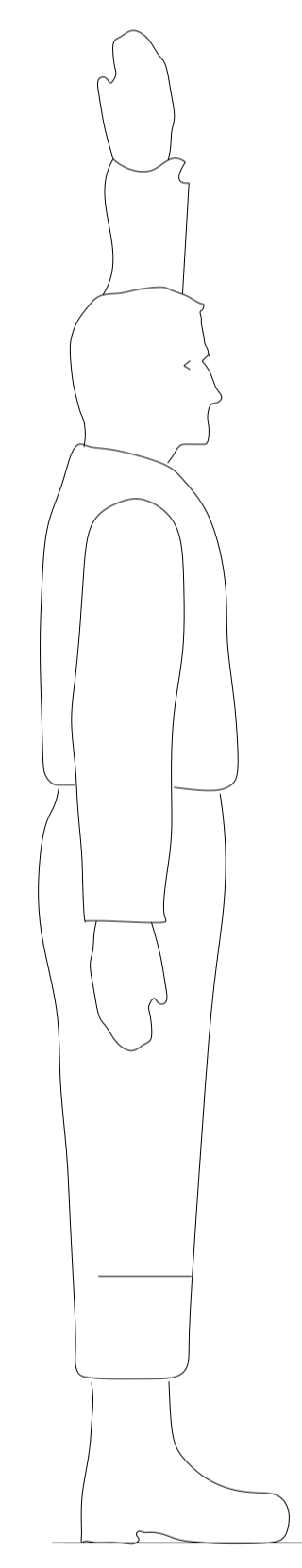

5' 10"  
[1778]

96.1  
[2440]

27.1  
[687]

202.40  
[5140.9]

139.41  
[3541.0]

139.08  
[3532.5]

AIR OUTLET

AIR INLET

SIDE MARKER  
(RED)

91.1  
[2313]

2X 22.2  
[564]

SIDE MARKER  
(AMBER)

31.8  
[807]

23.3  
[591]

36.7  
[932]

12.5  
[318]

VIEW A

8 7 6 5 4 3 2 1

<small>         PROPRIETARY NOTICE          THIS DRAWING CONTAINS CONFIDENTIAL AND TRADE SECRET INFORMATION. IT IS THE PROPERTY OF DOOSAN INFRASTRUCTURE INTERNATIONAL, INC. AND IS LOANED TO THE RECIPIENT IN CONFIDENCE. THE RECIPIENT BY RECEIVING AND REVIEWING OF THE DRAWING ACCEPTS THE DRAWING IN CONFIDENCE AND AGREES THAT: EXCEPT AS AUTHORIZED IN WRITING BY DOOSAN INFRASTRUCTURE INTERNATIONAL, INC. IT WILL (1) NOT USE, REPRODUCE OR ANY COPY THEREOF OR THE CONFIDENTIAL OR TRADE SECRET INFORMATION HEREIN; (2) NOT COPY, REPRODUCE, OR ANY COPY THEREOF; (3) NOT DISCLOSE TO OTHERS EITHER THE DRAWING OR THE CONFIDENTIAL OR TRADE SECRET INFORMATION HEREIN; AND (4) UPON COMPLETION OF THE NEED TO RETAIN THE DRAWING OR UPON DEMAND, RETURN THE DRAWING, ALL COPIES THEREOF, AND ALL MATERIAL COPIED THEREFROM.       </small>		<small>TITLE</small> <b>GENERAL ARRANGEMENT</b>			
<small>SIZE</small> <b>A1</b>	<small>DWG NO.</small> <b>46556182</b>	<small>REV</small> <b>A</b>		<small>SHEET 2 OF 6</small>	
<small>SCALE:</small> <b>0.03</b>					

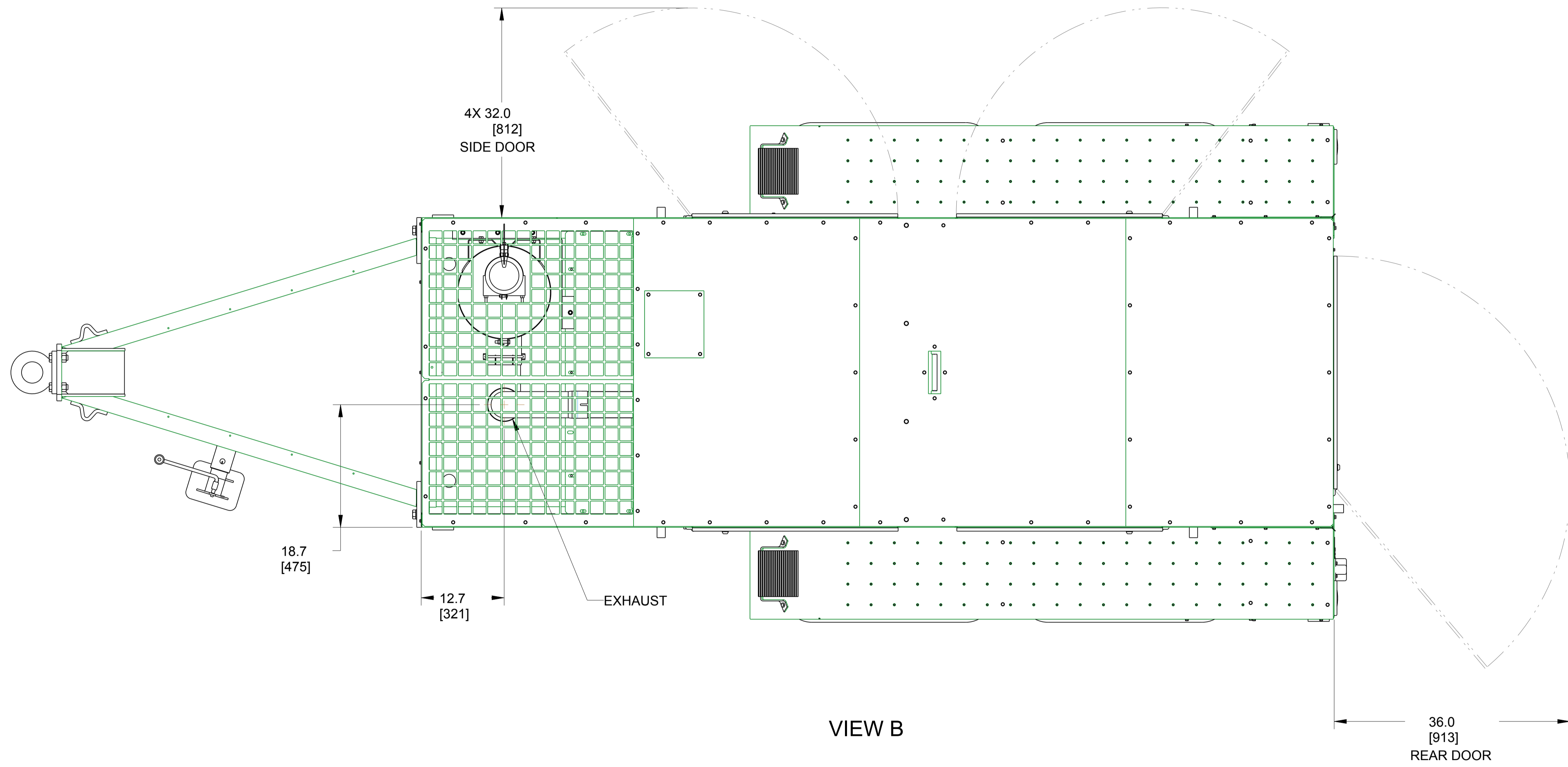

VIEW B

<small>PROPRIETARY NOTICE</small> <small>THIS DRAWING CONTAINS CONFIDENTIAL AND TRADE SECRET INFORMATION. IT IS THE PROPERTY OF DOOSAN INFRASTRUCTURE INTERNATIONAL, INC. AND IS LOANED TO THE RECIPIENT IN CONFIDENCE. THE RECIPIENT BY RECEIVING AND REVIEWING OF THE DRAWING ACCEPTS THE DRAWING IN CONFIDENCE AND AGREES THAT: EXCEPT AS AUTHORIZED IN WRITING BY DOOSAN INFRASTRUCTURE INTERNATIONAL, INC. IT WILL (1) NOT USE, THE DRAWING OR ANY COPY THEREOF OR THE CONFIDENTIAL OR TRADE SECRET INFORMATION THEREIN; (2) NOT COPY, REPRODUCE, DISSEMINATE, OR OTHERWISE DISCLOSE TO OTHERS EITHER THE DRAWING OR THE CONFIDENTIAL OR TRADE SECRET INFORMATION THEREIN; AND (3) UPON COMPLETION OF THE NEED TO RETAIN THE DRAWING OR UPON DEMAND, RETURN THE DRAWING, ALL COPIES THEREOF, AND ALL MATERIAL COPIED THEREFROM.</small>		<small>TITLE</small> <b>GENERAL ARRANGEMENT</b>			
<small>SIZE</small> <b>A1</b>	<small>DWG NO.</small> <b>46556182</b>	<small>REV</small> <b>A</b>			
<small>SCALE</small> <b>0.03</b>	<small>SHEET 3 OF 6</small>				

8 7 6 5 4 3 2 1

D C B A

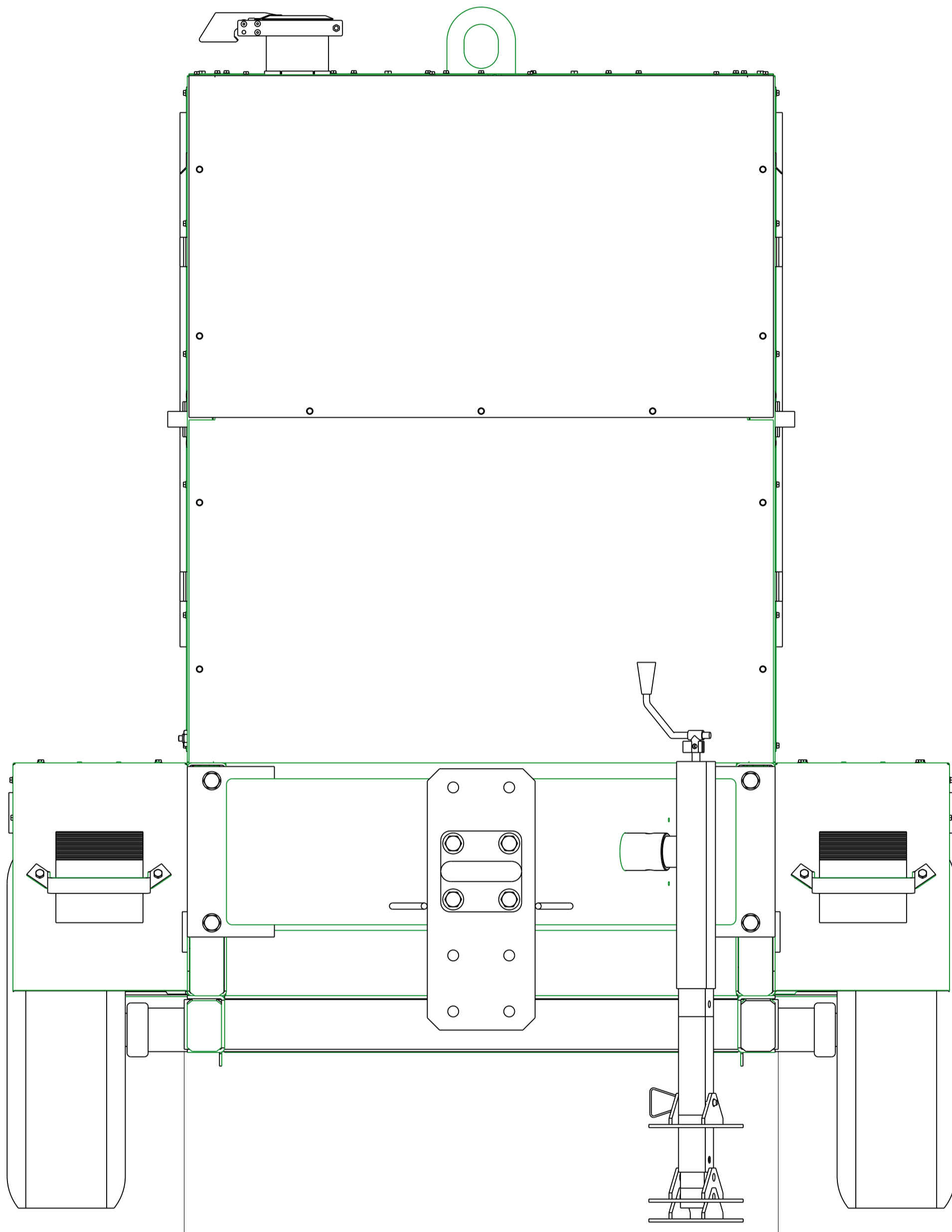

47.7  
[1213]  
FRAME WIDTH

VIEW C

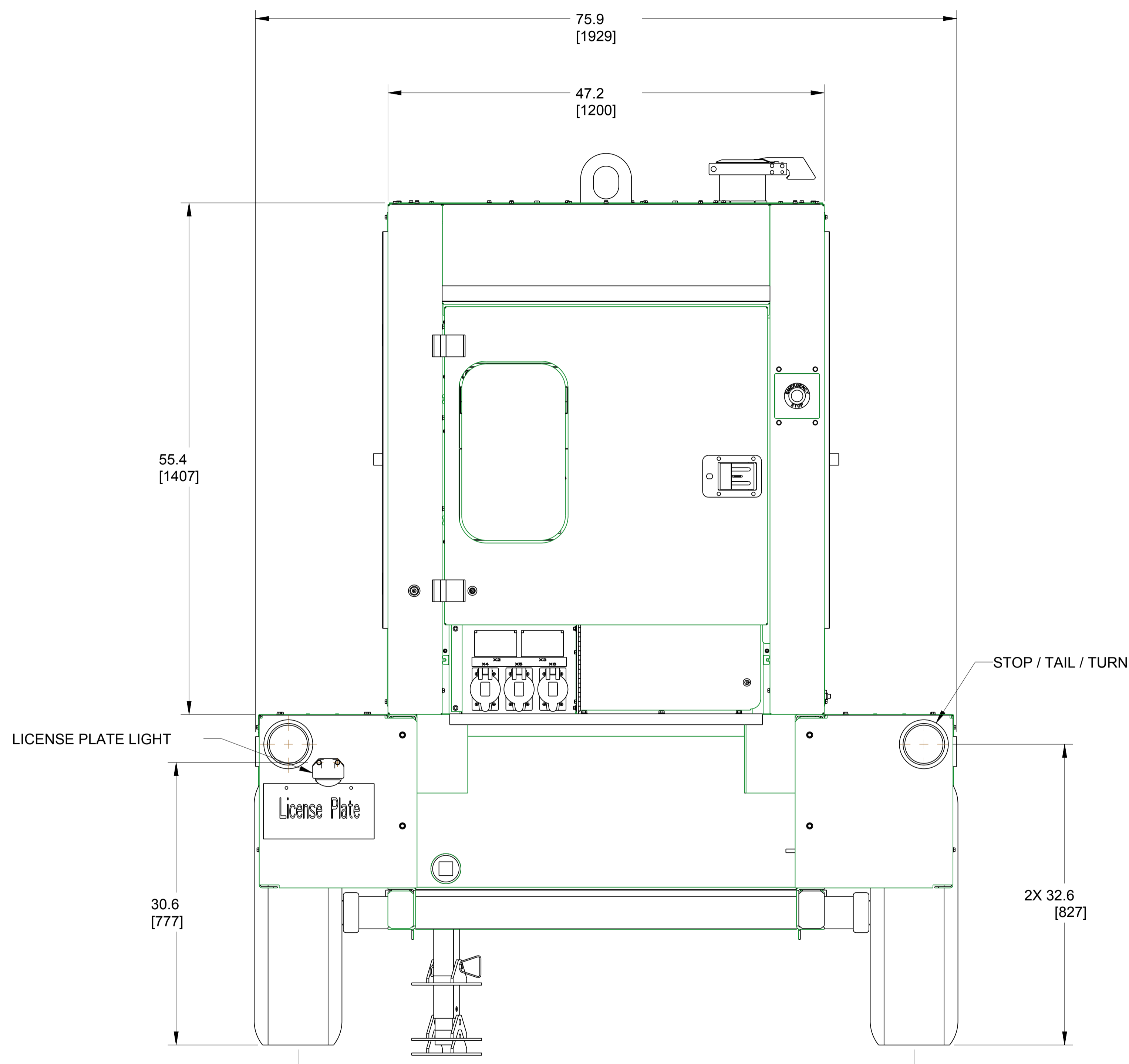

LICENSE PLATE LIGHT

License Plate

STOP / TAIL / TURN

55.4  
[1407]

75.9  
[1929]

47.2  
[1200]

30.6  
[777]

66.7  
[1694]  
TRACK WIDTH

2X 32.6  
[827]

VIEW D

8 7 6 5 4 3 2 1

UNLESS OTHERWISE SPECIFIED PRINTED DOCUMENT IS UNCONTROLLED

<small>PROPRIETARY NOTICE</small> <small>THIS DRAWING CONTAINS CONFIDENTIAL AND TRADE SECRET INFORMATION. IT IS THE PROPERTY OF DOOSAN INFRASTRUCTURE INTERNATIONAL, INC. AND IS GIVEN TO THE RECEIVER IN CONFIDENCE. THE RECEIVER BY RECEIVING AND REPRODUCING OF THE DRAWING ACCEPTS THE DRAWING IN CONFIDENCE AND AGREES THAT: EXCEPT AS AUTHORIZED IN WRITING BY DOOSAN INFRASTRUCTURE INTERNATIONAL, INC. IT WILL (1) NOT USE THE DRAWING OR ANY COPY THEREOF OR THE CONFIDENTIAL OR TRADE SECRET INFORMATION THEREIN; (2) NOT COPY THE DRAWING; (3) NOT DISCLOSE TO OTHERS EITHER THE DRAWING OR THE CONFIDENTIAL OR TRADE SECRET INFORMATION THEREIN; AND (4) UPON COMPLETION OF THE NEED TO RETAIN THE DRAWING OR UPON DEMAND, RETURN THE DRAWING, ALL COPIES THEREOF, AND ALL MATERIAL COPIED THEREFROM.</small>		<small>TITLE</small> <b>GENERAL ARRANGEMENT</b>			
<small>SIZE</small> <b>A1</b>	<small>DWG NO.</small> <b>46556182</b>	<small>REV</small> <b>A</b>		<small>SHEET</small> <b>4 OF 6</b>	
<small>SCALE</small> <b>0.03</b>					

8 7 6 5 4 3 2 1

D C B A

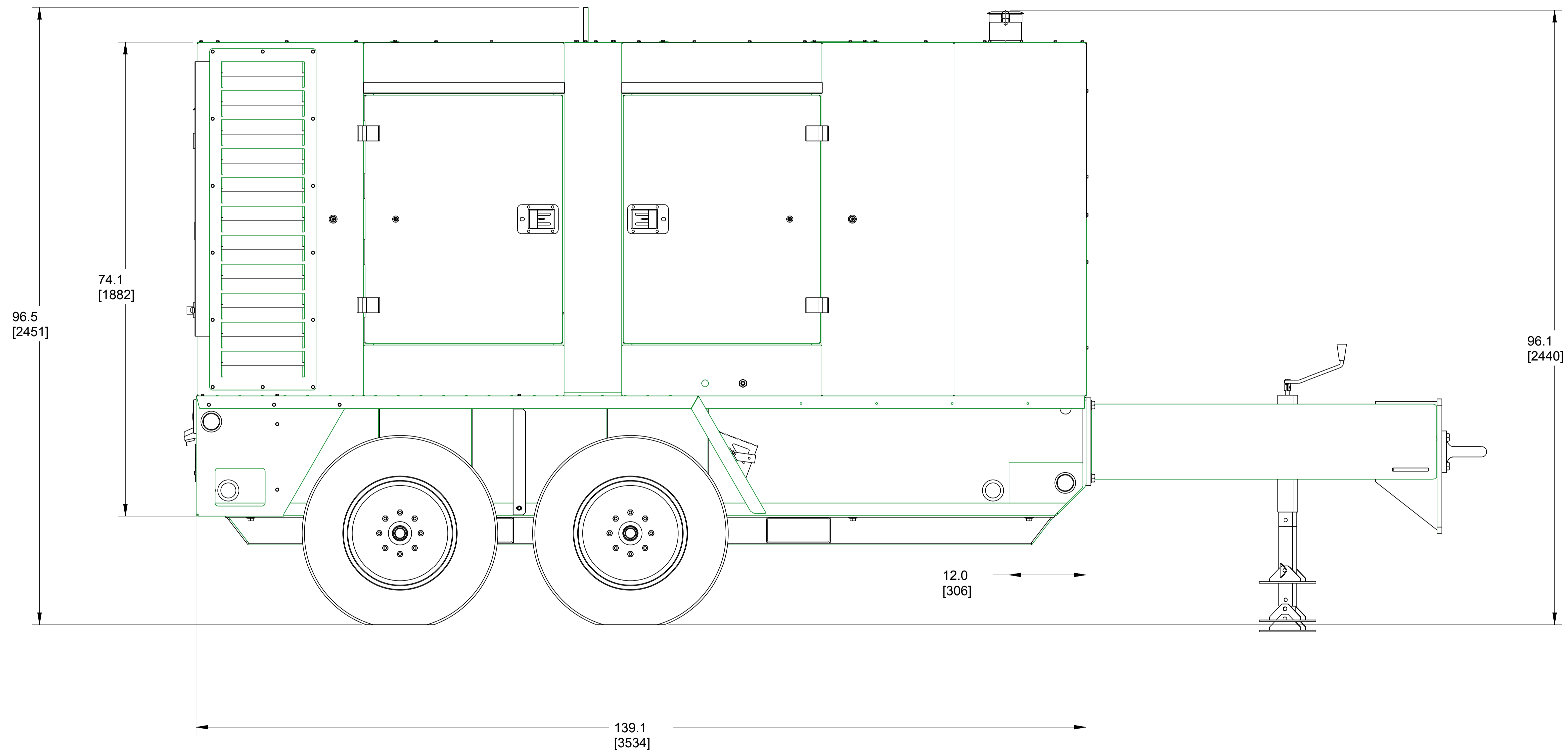

VIEW E-E

1
A8

<small>PROPRIETARY NOTICE</small> <small>THIS DRAWING CONTAINS CONFIDENTIAL AND TRADE SECRET INFORMATION. IT IS THE PROPERTY OF DOOSAN INFRACORE INTERNATIONAL, INC. AND IS LOANED TO THE RECIPIENT IN CONFIDENCE. THE RECIPIENT BY RECEIVING AND REVIEWING OF THE DRAWING ACCEPTS THE DRAWING IN CONFIDENCE AND AGREES THAT: EXCEPT AS AUTHORIZED IN WRITING BY DOOSAN INFRACORE INTERNATIONAL, INC. IT WILL (1) NOT USE, THE DRAWING OR ANY COPY THEREOF OR THE CONFIDENTIAL OR TRADE SECRET INFORMATION THEREIN; (2) NOT COPY, REPRODUCE, DISSEMINATE, OR OTHERWISE DISCLOSE TO OTHERS EITHER THE DRAWING OR THE CONFIDENTIAL OR TRADE SECRET INFORMATION THEREIN; AND (3) UPON COMPLETION OF THE NEED TO RETAIN THE DRAWING OR UPON DEMAND, RETURN THE DRAWING, ALL COPIES THEREOF, AND ALL MATERIAL COPIED THEREFROM.</small>		<small>TITLE</small> <b>GENERAL ARRANGEMENT</b>		
<small>SIZE</small> <b>A1</b>	<small>DWG NO.</small> <b>46556182</b>	<small>REV</small> <b>A</b>		
<small>SCALE</small> <b>0.03</b>	<small>SHEET 5 OF 6</small>			

8 7 6 5 4 3 2 1

8 7 6 5 4 3 2 1

D  
C  
B  
A

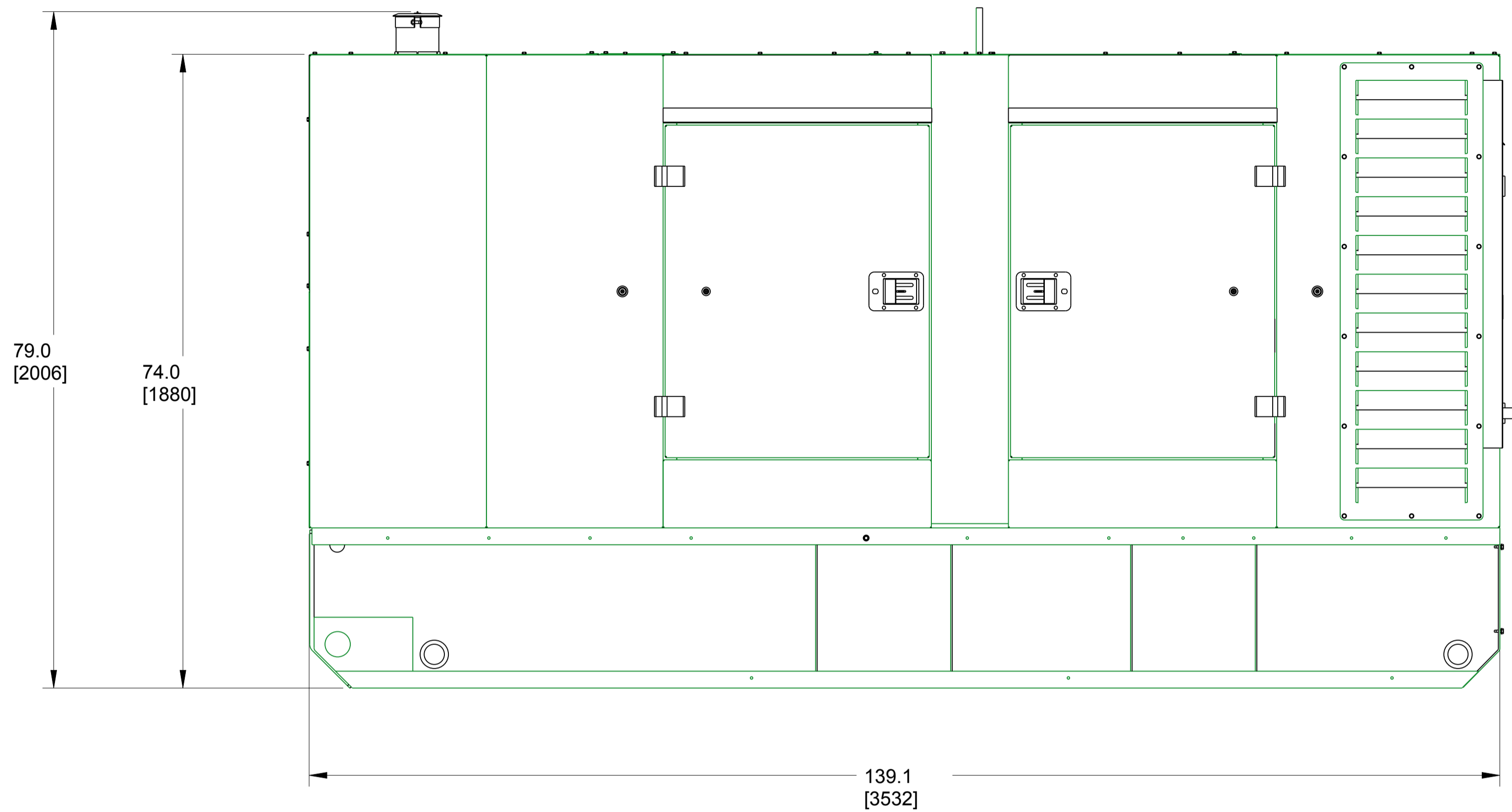

LESS RUNNING GEAR OPTION  
(LEFT VIEW)

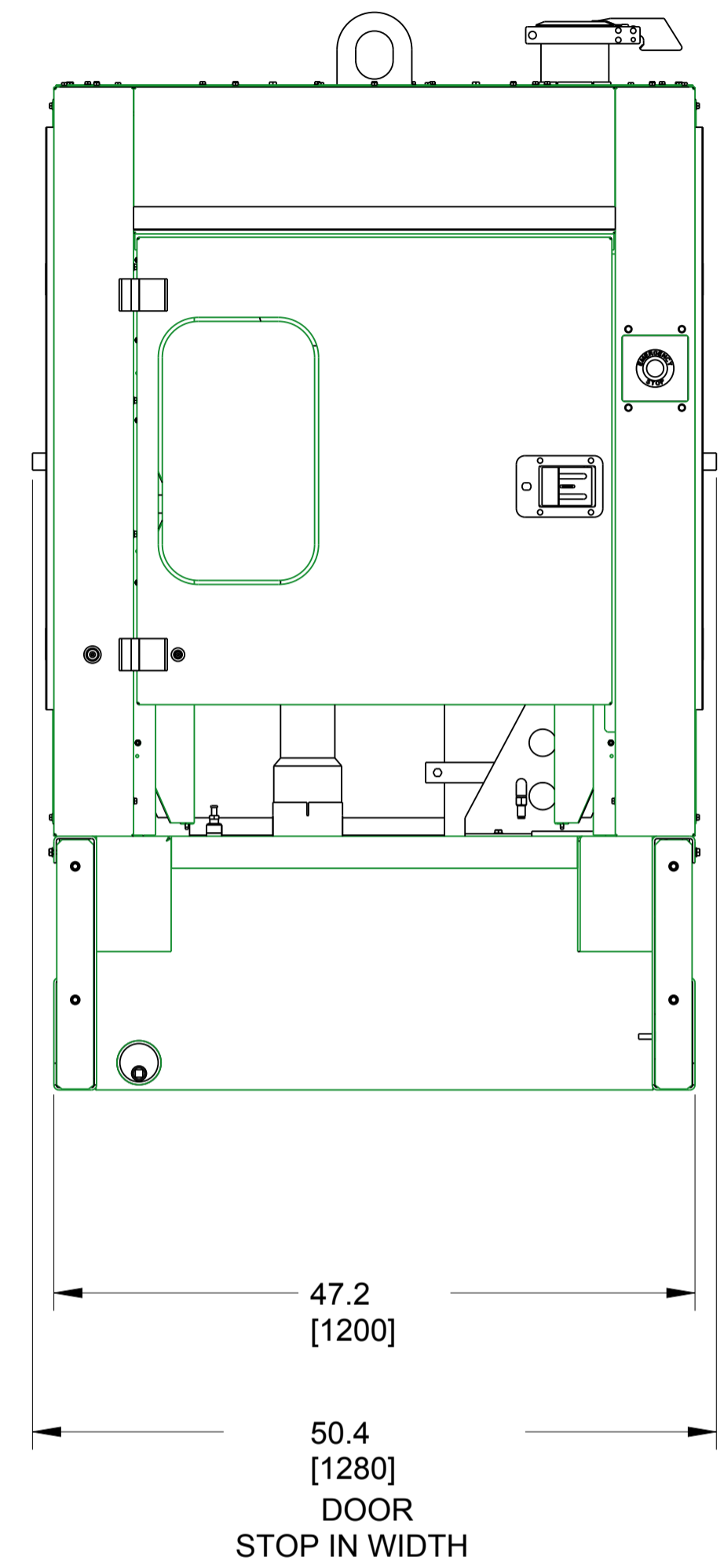

LESS RUNNING GEAR OPTION  
(CONTROLS VIEW)

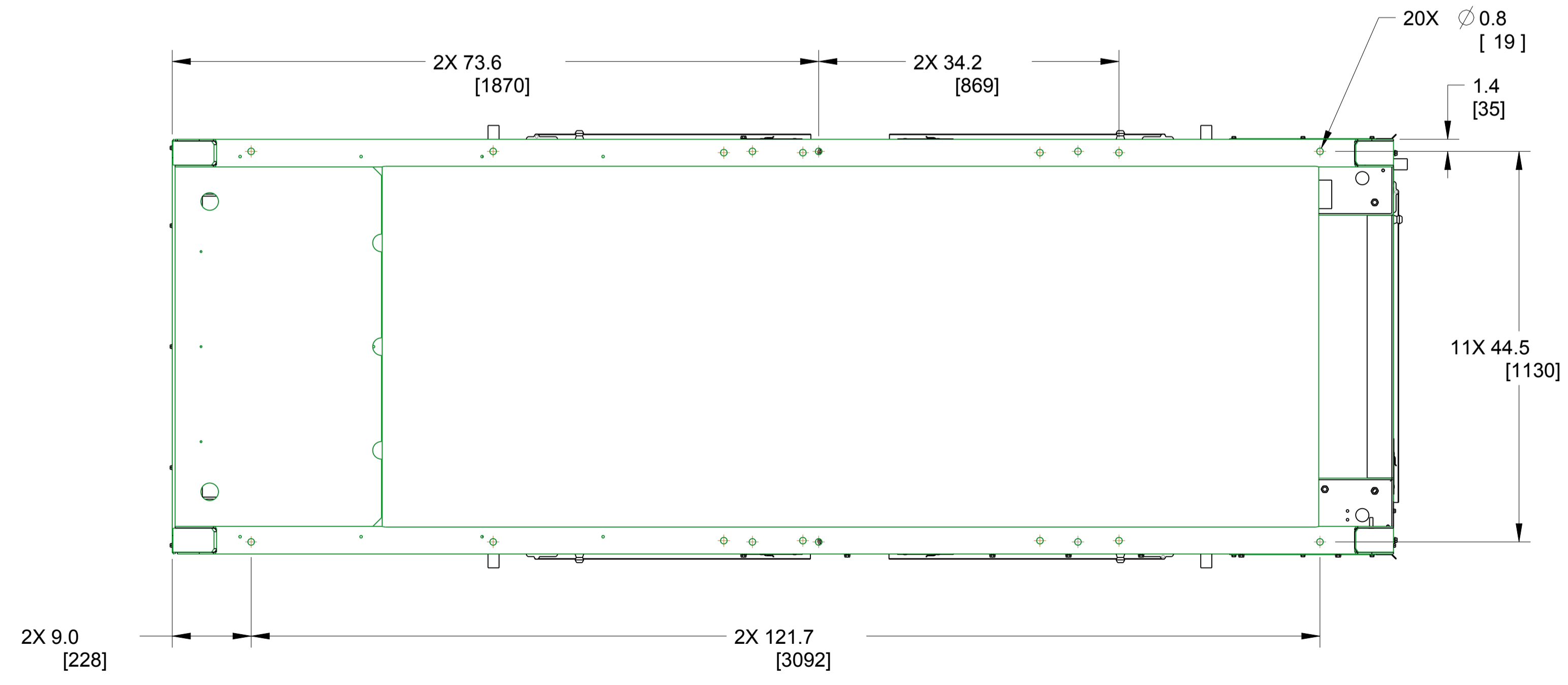

LESS RUNNING GEAR OPTION  
(BOTTOM VIEW)

8 7 6 5 4 3 2 1

<small>PROPRIETARY NOTICE</small> THIS DRAWING CONTAINS CONFIDENTIAL AND TRADE SECRET INFORMATION IS THE PROPERTY OF DOOSAN INFRASTRUCTURE INTERNATIONAL, INC. AND IS GIVEN TO THE RECEIVER IN CONFIDENCE. THE RECEIVER BY RECEIVING AND RETENTION OF THE DRAWING ACCEPTS THE DRAWING IN CONFIDENCE AND AGREES THAT EXCEPT AS AUTHORIZED IN WRITING BY DOOSAN INFRASTRUCTURE INTERNATIONAL, INC. IT WILL NOT USE, THE DRAWING OR ANY COPY THEREOF OR THE CONFIDENTIAL OR TRADE SECRET INFORMATION THEREIN. DO NOT COPY THE DRAWING, DO NOT DISCLOSE TO OTHERS EITHER THE DRAWING OR THE CONFIDENTIAL OR TRADE SECRET INFORMATION THEREIN, AND UPON COMPLETION OF THE NEED TO RETAIN THE DRAWING OR UPON DEMAND, RETURN THE DRAWING, ALL COPIES THEREOF, AND ALL MATERIAL COPIED THEREFROM.		<small>TITLE</small> <b>GENERAL ARRANGEMENT</b>			
<small>SIZE</small> <b>A1</b>	<small>DWG NO.</small> <b>46556182</b>	<small>REV</small> <b>A</b>		<small>SCALE</small> <b>0.03</b>	
				<small>SHEET 6 OF 6</small>	