

REVISIONS							
ZONE	REV	ECN	DESCRIPTION	DATE	DRAWN	CHECKED	APP'D
-	Pro-A	-	RELEASED FOR PROTOTYPE	2014NOV18	CCR	KEF	CPB
-	2/B1	A	RELEASED FOR PRODUCTION WITH CHANGES ADDED DIM 1984.0 [78.11]	2015APR03	TTR	KEF	CPB
	B	-	UPDATED DIMENSIONS ON SHEET 2	2016FEB08	TTR	RAW	KEF

NOTES:

1. MINIMUM CLEARANCE OF 36 INCHES FROM OPPOSING SURFACES IS TO BE MAINTAINED ON ALL SIDES AND OVERHEAD DURING OPERATION.
2. DIMENSIONS ON DRAWING ARE DUAL WITH METRIC VALUE ON TOP AND INCH VALUE PLACED BELOW IN BRACKETS.

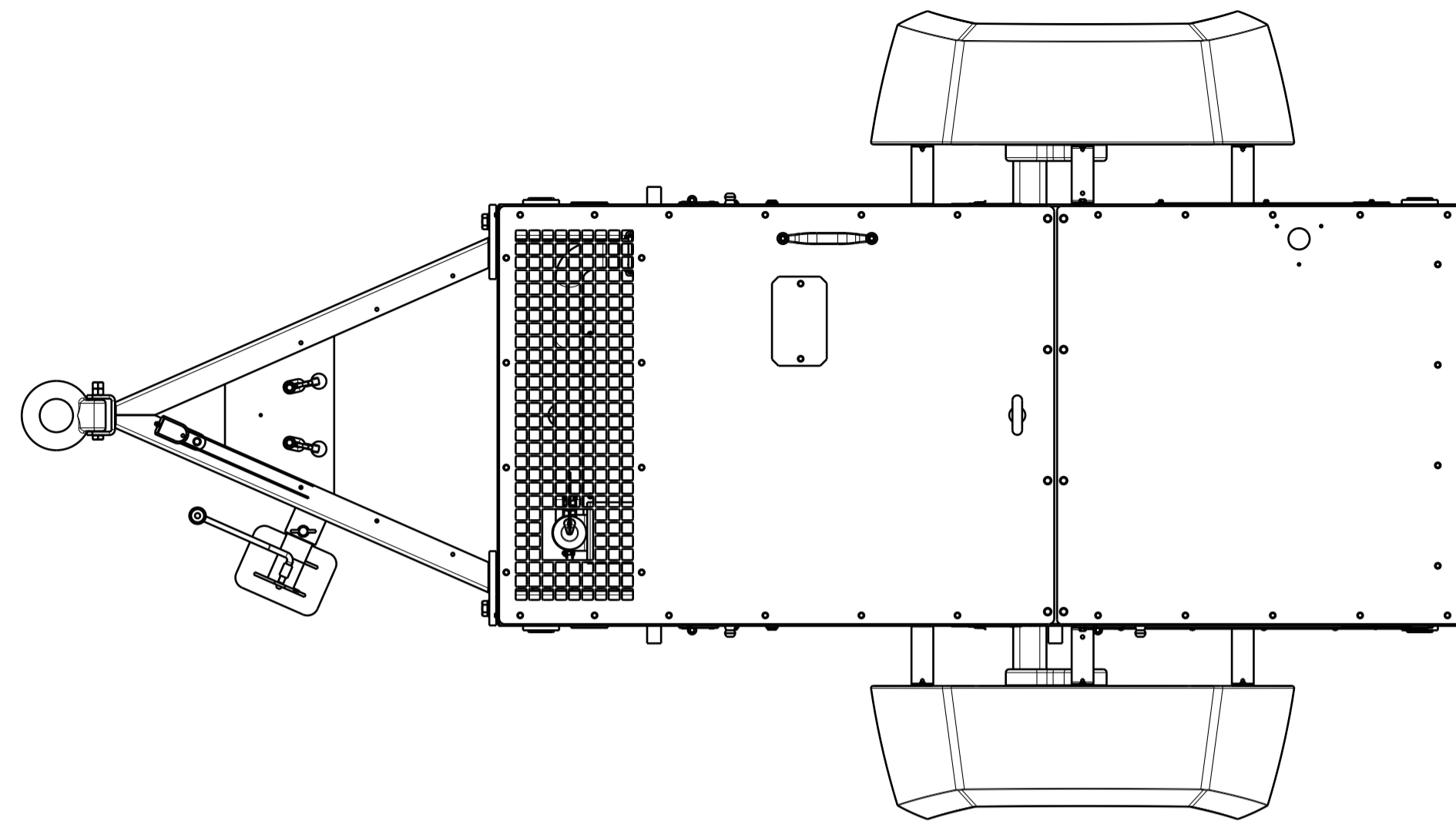

TOP VIEW
SEE SHEET 3 FOR ENLARGED VIEW

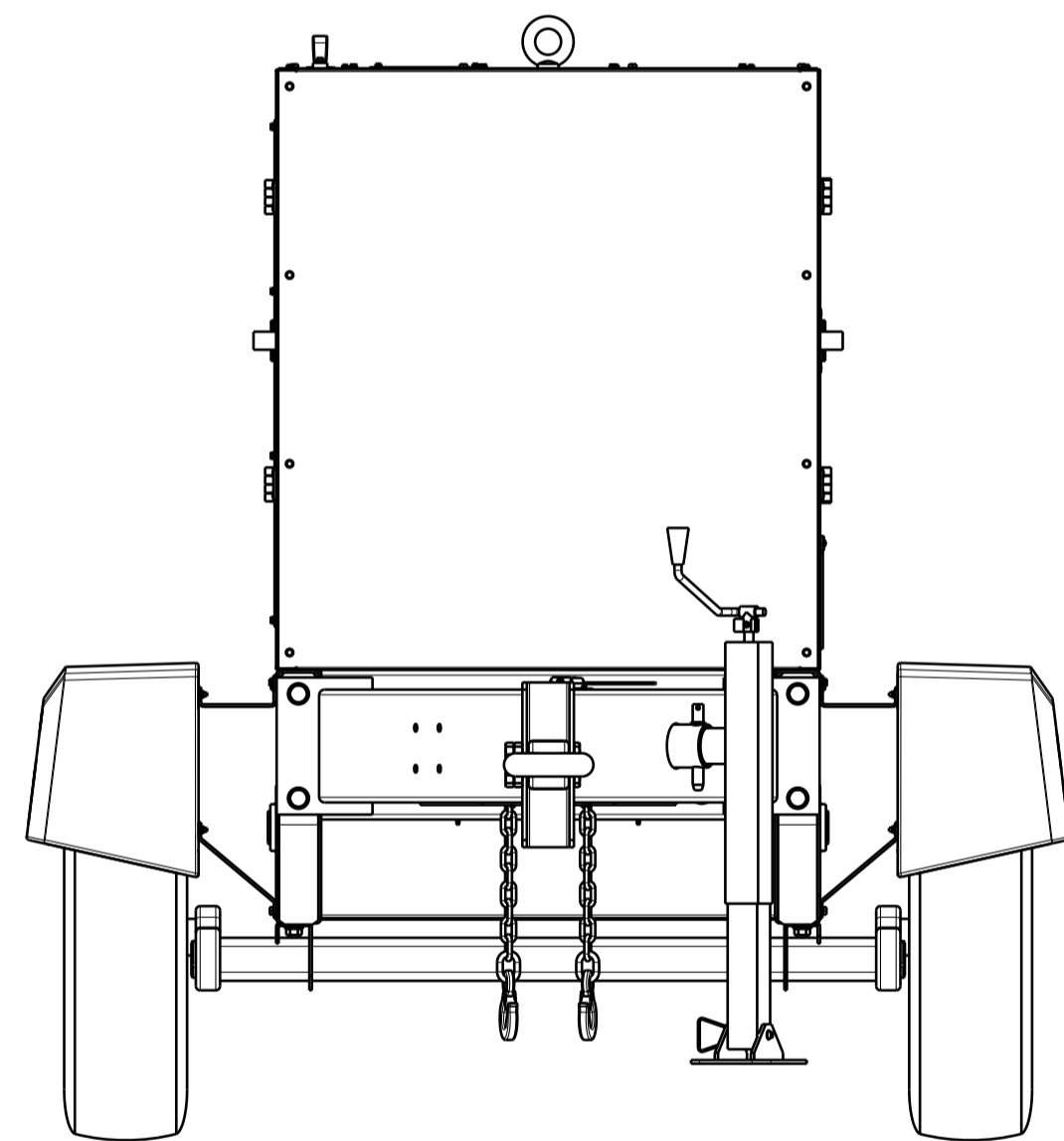

FRONT VIEW
SEE SHEET 4 FOR ENLARGED VIEW

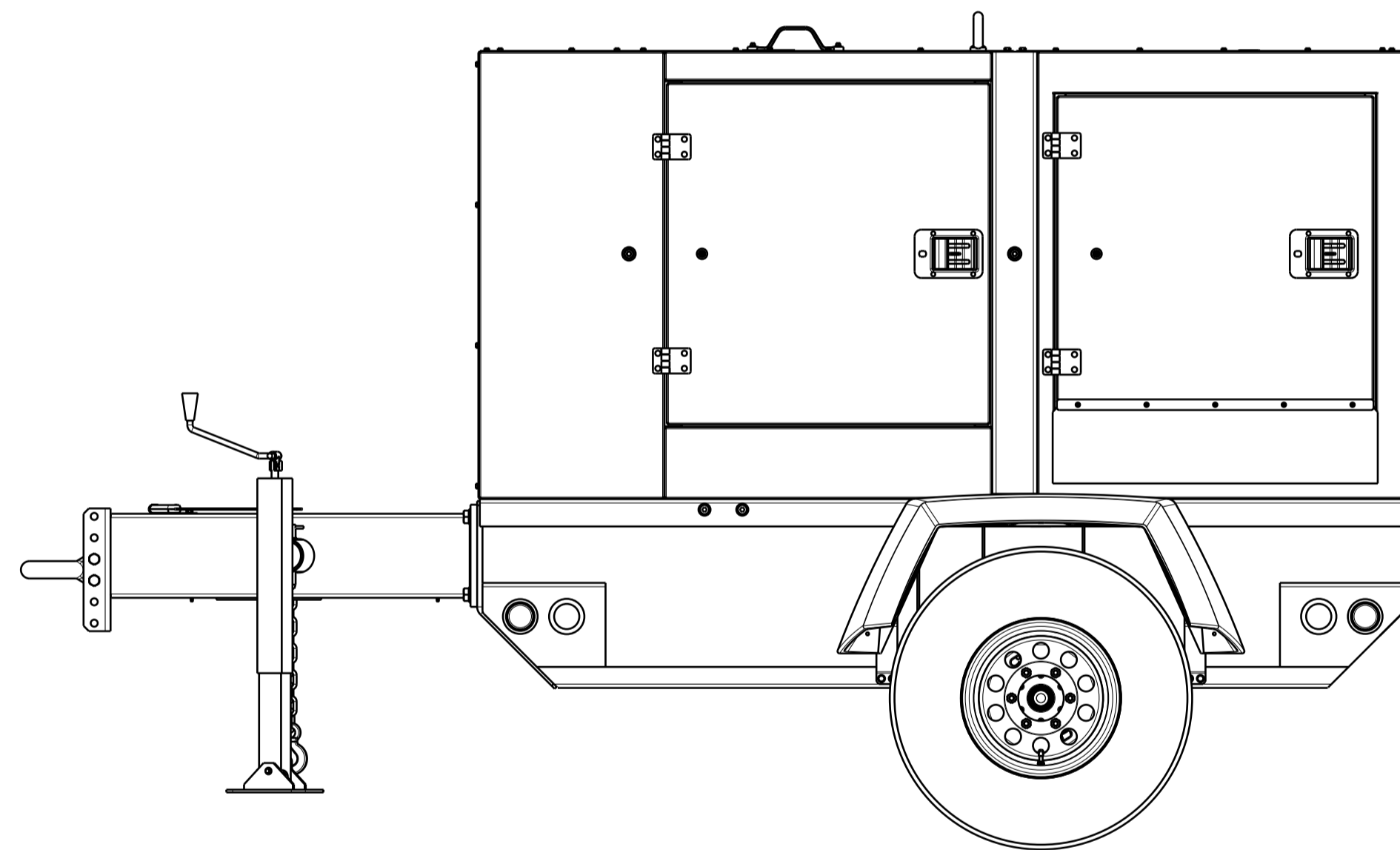

STREETSIDE VIEW
SEE SHEET 2 FOR ENLARGED VIEW

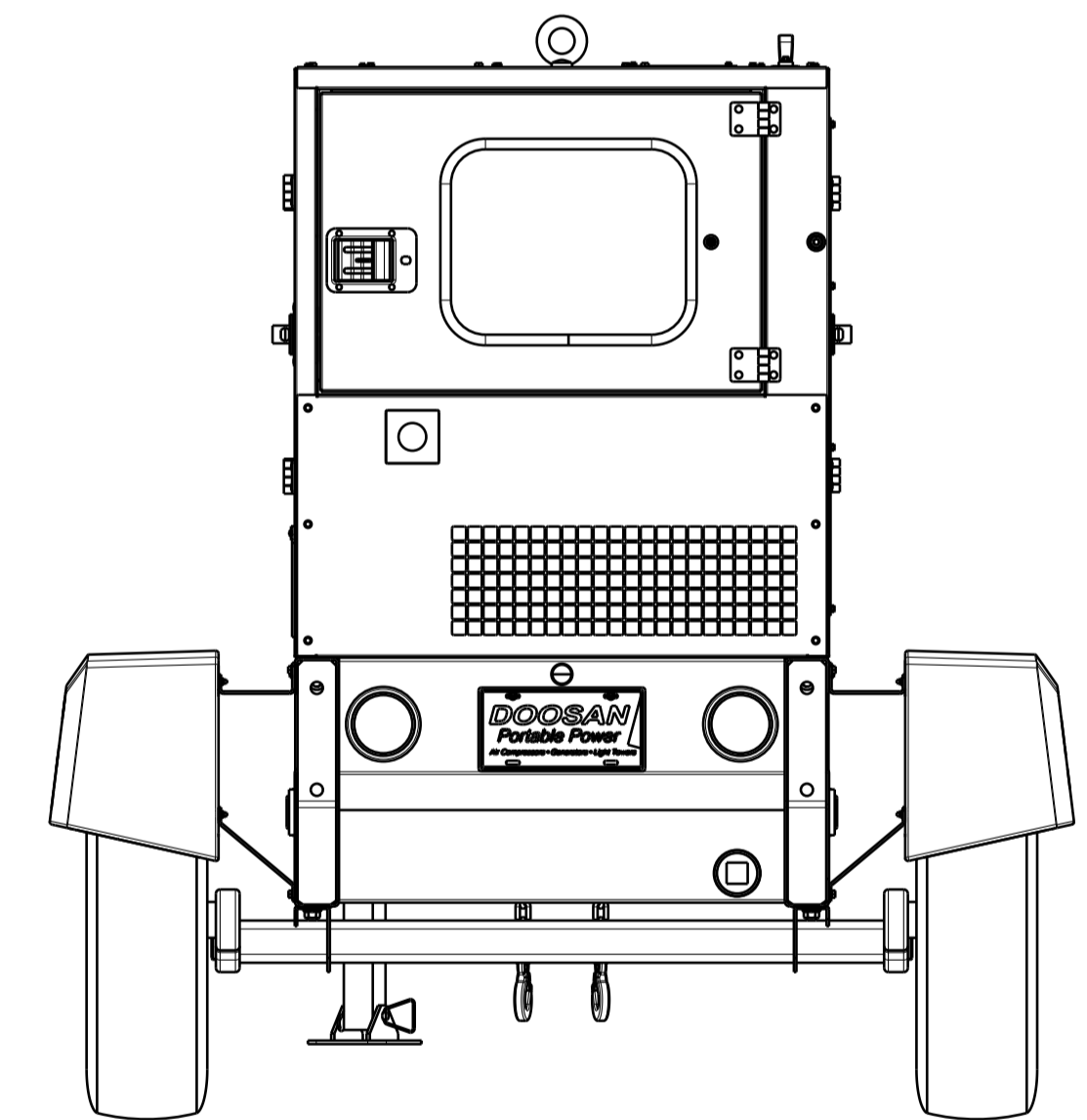

REAR VIEW
SEE SHEET 4 FOR ENLARGED VIEW

TOLERANCES UNLESS OTHERWISE SPECIFIED, TOLERANCES ON DIMENSIONS ARE AS SPECIFIED ON DRAWING 36865731 UNLESS OTHERWISE SPECIFIED, ALL DIMENSIONS ARE IN MILLIMETERS. <small>Doosan Infracore Portable Power</small>		PROPRIETARY NOTICE THIS DRAWING CONTAINS CONFIDENTIAL AND TRADE SECRET INFORMATION, IS THE PROPERTY OF DOOSAN INFRACORE AND IS GIVEN TO THE RECEIVER IN CONFIDENCE. THE RECEIVER BY RECEPTION AND RETENTION OF THE DRAWING ACCEPTS THE DRAWING IN CONFIDENCE AND AGREES THAT, EXCEPT AS AUTHORIZED IN WRITING BY DOOSAN INFRACORE IT WILL (1) NOT USE THE DRAWING COPY THEREOF OR THE CONFIDENTIAL OR TRADE SECRET OR ANY INFORMATION THEREIN; (2) NOT COPY THE DRAWING; (3) NOT DISCLOSE TO OTHERS EITHER THE DRAWING OR THE CONFIDENTIAL OR TRADE SECRET INFORMATION THEREIN; AND (4) UPON COMPLETION OF THE NEED TO RETAIN THE DRAWING, OR UPON DEMAND, RETURN THE DRAWING, ALL COPIES THEREOF, AND ALL MATERIAL COPIED THEREFROM.		WARNING: THE EXPORT OR REEXPORT OF THIS DRAWING OR A PRODUCT PRODUCED BY THIS DRAWING IS SUBJECT TO U.S. EXPORT ADMINISTRATION REGULATIONS AND OTHER APPLICABLE GOVERNMENT RESTRICTIONS OR REGULATIONS. COPYRIGHT © 2016 DOOSAN INFRACORE PORTABLE POWER ALL RIGHTS RESERVED DO NOT SCALE DRAWING		 THIRD ANGLE PROJECTION WELD SYMBOLS PER ANSI/AWS A2.4 DRAWING CONFORMS TO ASME Y14.5 - 2009		 Doosan Infracore Portable Power CAD GENERATED DRAWING, NO MANUAL REVISIONS ALLOWED UNLESS OTHERWISE SPECIFIED, REMOVE ALL BURRS AND SHARP CORNERS SIZE: A1 ESTIMATED WEIGHT: - DWG NO.: 46671208 SCALE: N/A UNIT: G50 T4F REV: B SHEET 1 OF 6	
ASSY REF DWG, GENERAL ARRANGEMENT G50 T4F									

8 7 6 5 4 3 2 1

D
C
B
A

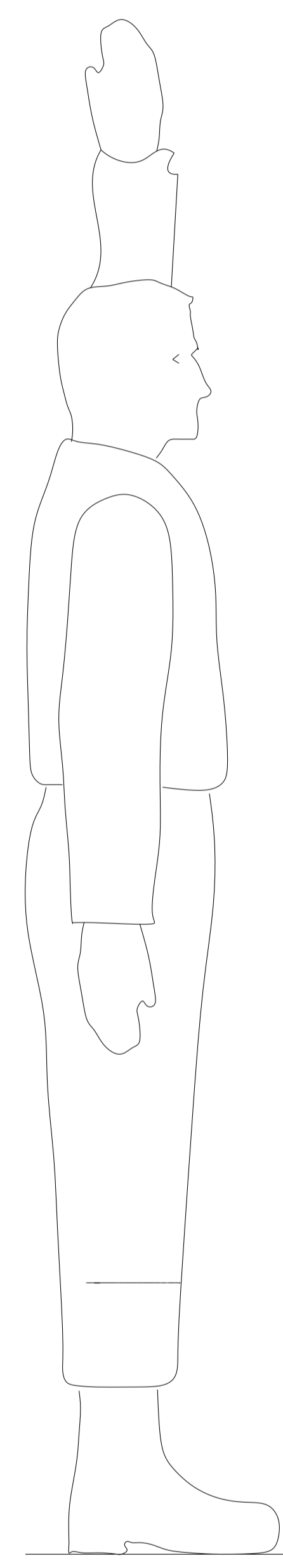

5' 10"
[1778]

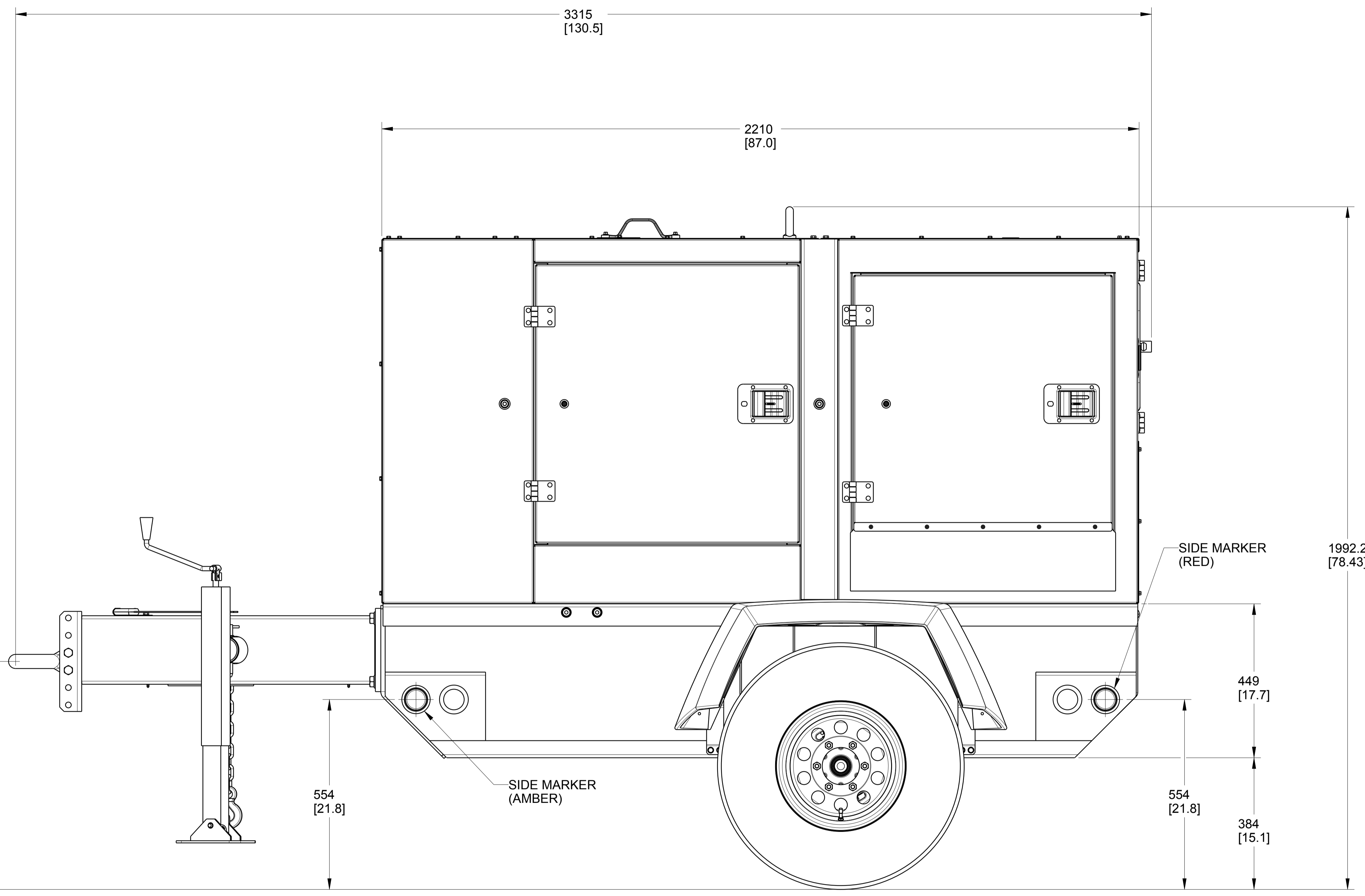

3315
[130.5]

2210
[87.0]

665
[26.2]

554
[21.8]

SIDE MARKER
(AMBER)

SIDE MARKER
(RED)

1992.2
[78.43]

449
[17.7]

554
[21.8]

384
[15.1]

STREETSIDE VIEW

PROPRIETARY NOTICE: THIS DRAWING CONTAINS CONFIDENTIAL AND TRADE SECRET INFORMATION, IS THE PROPERTY OF DOOSAN INFRACORE INTERNATIONAL, INC. AND IS GIVEN TO THE RECEIVER IN CONFIDENCE. THE RECEIVER BY ACCEPTANCE AND RETENTION OF THE DRAWING ACCEPTS THE DRAWING IN CONFIDENCE AND AGREES THAT, EXCEPT AS AUTHORIZED IN WRITING BY DOOSAN INFRACORE INTERNATIONAL, INC., IT WILL (1) NOT USE THE DRAWING OR ANY COPY THEREOF OR THE CONFIDENTIAL OR TRADE SECRET INFORMATION THEREIN; (2) NOT COPY THE DRAWING; (3) NOT DISCLOSE TO OTHERS EITHER THE CONFIDENTIAL OR TRADE SECRET INFORMATION THEREIN; AND (4) UPON COMPLETION OF THE NEED TO RETAIN THE DRAWING, OR UPON DEMAND, RETURN THE DRAWING, ALL COPIES THEREOF, AND ALL MATERIAL COPIED THEREFROM.

	ESTIMATED WEIGHT (KG UNLESS OTHERWISE SPECIFIED)	SCALE:	N/A	SIZE:	A1	DWG NO.:	46671208	REV:	B
	UNIT:	G50 T4F		SHEET 2 OF 6					
TITLE: ASSY REF DWG, GENERAL ARRANGEMENT G50 T4F									

8 7 6 5 4 3 2 1

DOOSAN_FORMAT.FRM
REV: H

8 7 6 5 4 3 2 1

D
C
B
A

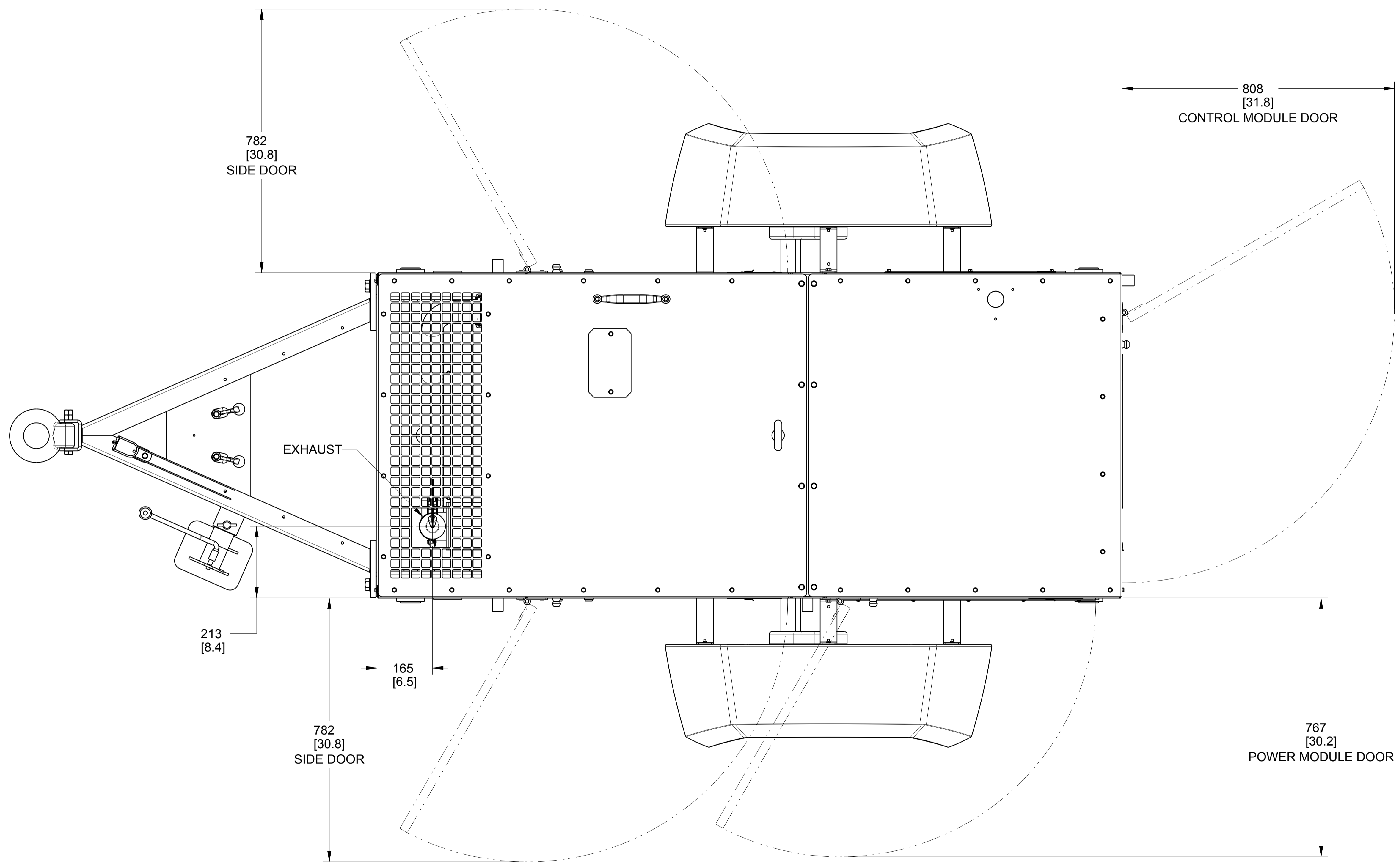

TOP VIEW

8 7 6 5 4 3 2 1

UNLESS OTHERWISE SPECIFIED PRINTED DOCUMENT IS UNCONTROLLED

DOOSAN

PROPRIETARY NOTICE: THIS DRAWING CONTAINS CONFIDENTIAL AND TRADE SECRET INFORMATION, IS THE PROPERTY OF DOOSAN INFRACORE INTERNATIONAL, INC. AND IS GIVEN TO THE RECEIVER IN CONFIDENCE. THE RECEIVER BY RECEPTION AND RETENTION OF THE DRAWING ACCEPTS THE DRAWING IN CONFIDENCE AND AGREES THAT, EXCEPT AS AUTHORIZED IN WRITING BY DOOSAN INFRACORE INTERNATIONAL, INC., IT WILL (1) NOT USE THE DRAWING OR ANY COPY THEREOF OR THE CONFIDENTIAL OR TRADE SECRET INFORMATION THEREIN; (2) NOT COPY, REPRODUCE, OR DISCLOSE TO OTHERS EITHER THE DRAWING OR THE CONFIDENTIAL OR TRADE SECRET INFORMATION THEREIN; AND (3) UPON COMPLETION OF THE NEED TO RETAIN THE DRAWING, OR UPON DEMAND, RETURN THE DRAWING, ALL COPIES THEREOF, AND ALL MATERIAL COPIED THEREFROM.

ESTIMATED WEIGHT (KG UNLESS OTHERWISE SPECIFIED):	SCALE:	SIZE:	DWG NO.:	REV:
N/A	N/A	A1	46671208	B
TITLE:			UNIT:	
ASSY REF DWG, GENERAL ARRANGEMENT G50 T4F			G50 T4F	SHEET 3 OF 6

DOOSAN_FORMAT.FRM
REV: H

8 7 6 5 4 3 2 1

D C B A

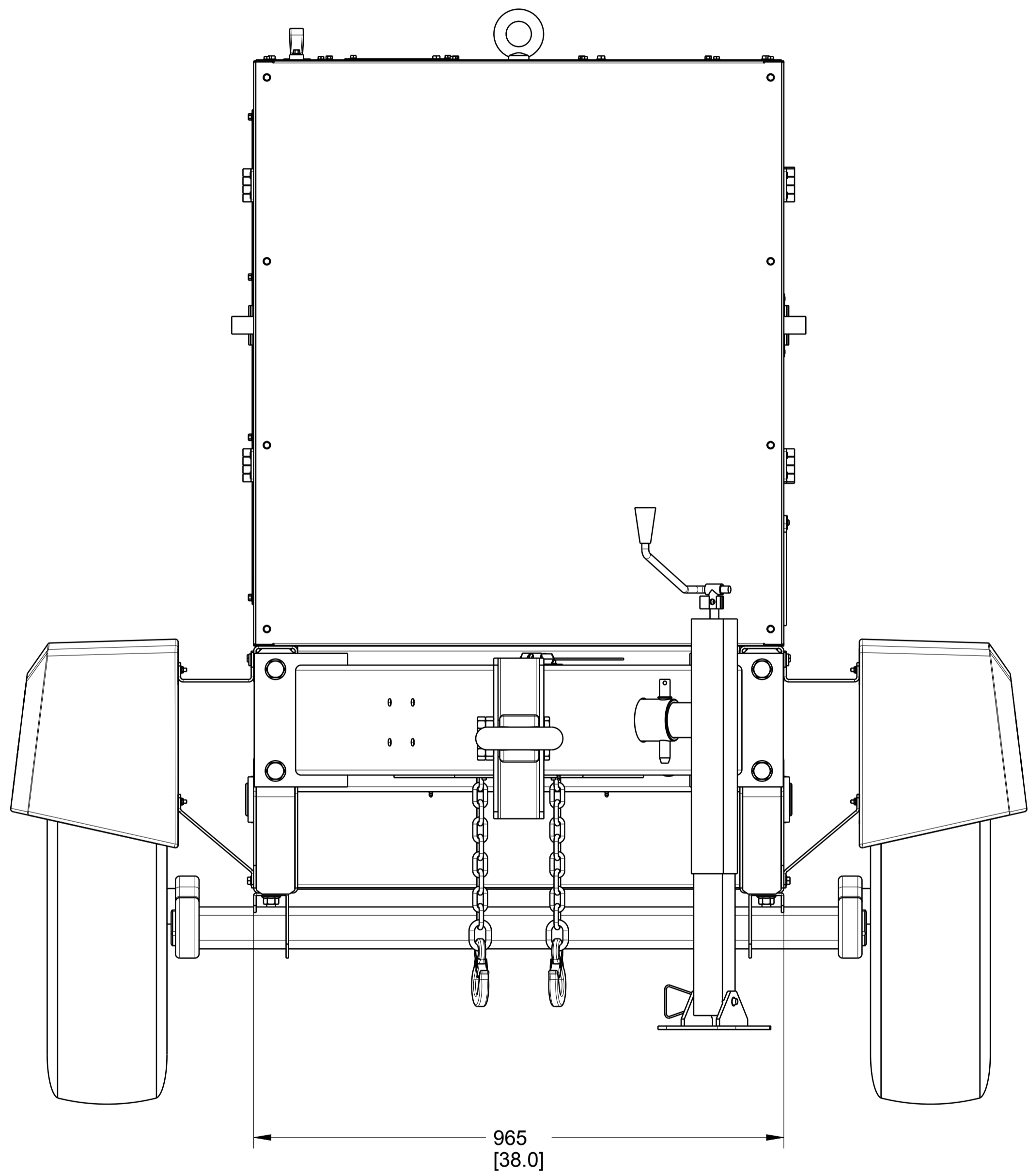

FRONT VIEW

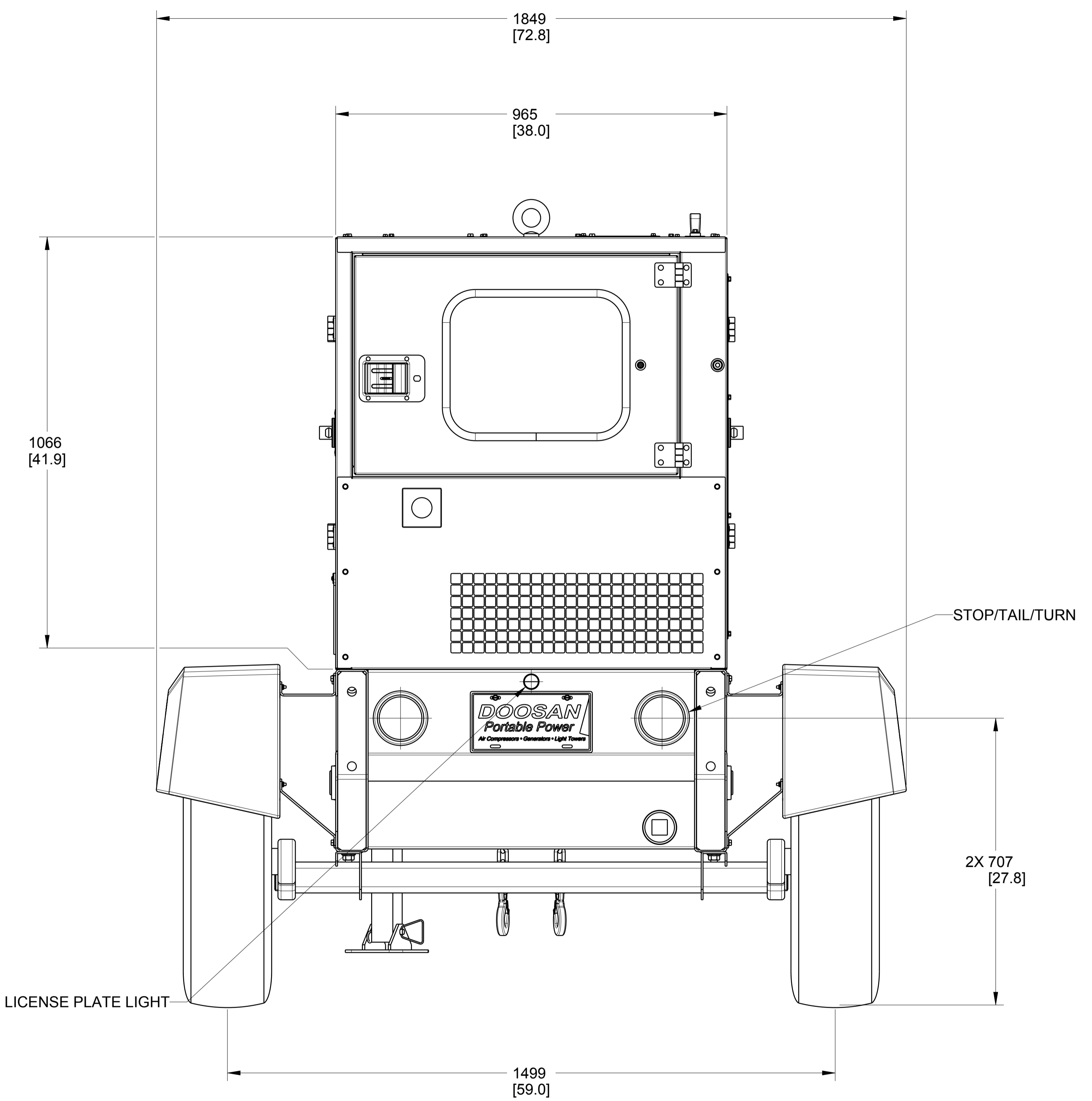

REAR VIEW

8 7 6 5 4 3 2 1

UNLESS OTHERWISE SPECIFIED PRINTED DOCUMENT IS UNCONTROLLED

PROPRIETARY NOTICE: THIS DRAWING CONTAINS CONFIDENTIAL AND TRADE SECRET INFORMATION, IS THE PROPERTY OF DOOSAN INFRACORE INTERNATIONAL, INC. AND IS GIVEN TO THE RECEIVER IN CONFIDENCE. THE RECEIVER BY RECEPTION AND RETENTION OF THE DRAWING ACCEPTS THE DRAWING IN CONFIDENCE AND AGREES THAT, EXCEPT AS AUTHORIZED IN WRITING BY DOOSAN INFRACORE INTERNATIONAL, INC., IT WILL (1) NOT USE THE DRAWING OR ANY COPY THEREOF OR THE CONFIDENTIAL OR TRADE SECRET INFORMATION THEREIN; (2) NOT COPY THE DRAWING; (3) NOT DISCLOSE TO OTHERS EITHER THE DRAWING OR THE CONFIDENTIAL OR TRADE SECRET INFORMATION THEREIN; AND (4) UPON COMPLETION OF THE NEED TO RETAIN THE DRAWING, OR UPON DEMAND, RETURN THE DRAWING, ALL COPIES THEREOF, AND ALL MATERIAL COPIED THEREFROM.

DOOSAN	ESTIMATED WEIGHT (KG UNLESS OTHERWISE SPECIFIED)	SCALE	SIZE	DWG NO.	REV
	N/A	N/A	A1	46671208	B
TITLE	UNIT		SHEET 4 OF 6		
ASSY REF DWG, GENERAL ARRANGEMENT G50 T4F		G50 T4F			

DOOSAN_FORMAT.FRM REV: H

8 7 6 5 4 3 2 1

D
C
B
A

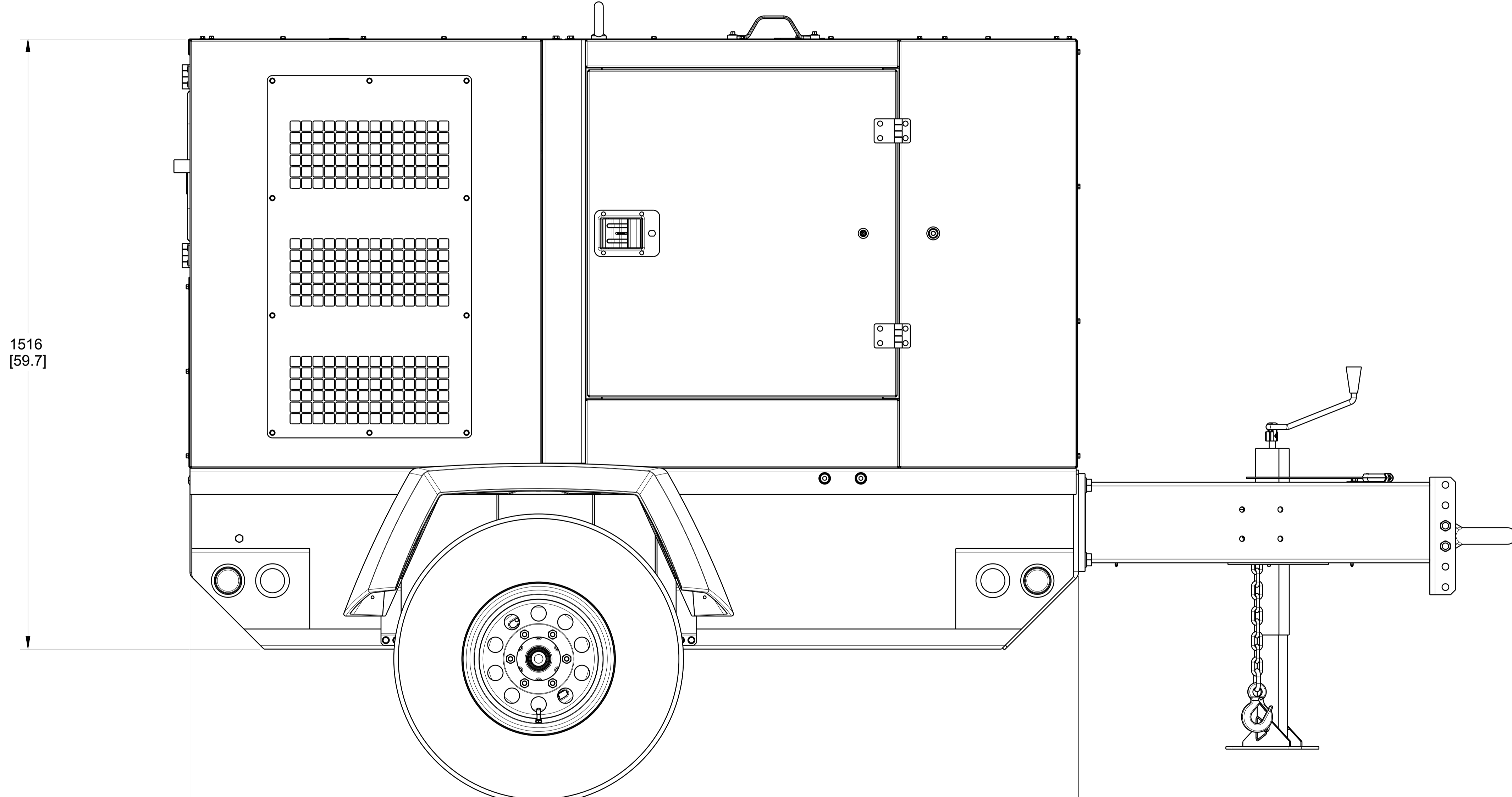

1516
[59.7]

2209
[87.0]

CURBSIDE VIEW

8 7 6 5 4 3 2 1

D
C
B
A

UNLESS OTHERWISE SPECIFIED PRINTED DOCUMENT IS UNCONTROLLED

DOOSAN ESTIMATED WEIGHT (KG UNLESS OTHERWISE SPECIFIED) SCALE: N/A SIZE: A1 DWG NO. 46671208 REV: B

TITLE: ASSY REF DWG, GENERAL ARRANGEMENT G50 T4F UNIT: G50 T4F SHEET 5 OF 6

DOOSAN_FORMAT.FRM
REV: H

8 7 6 5 4 3 2 1

D
C
B
A

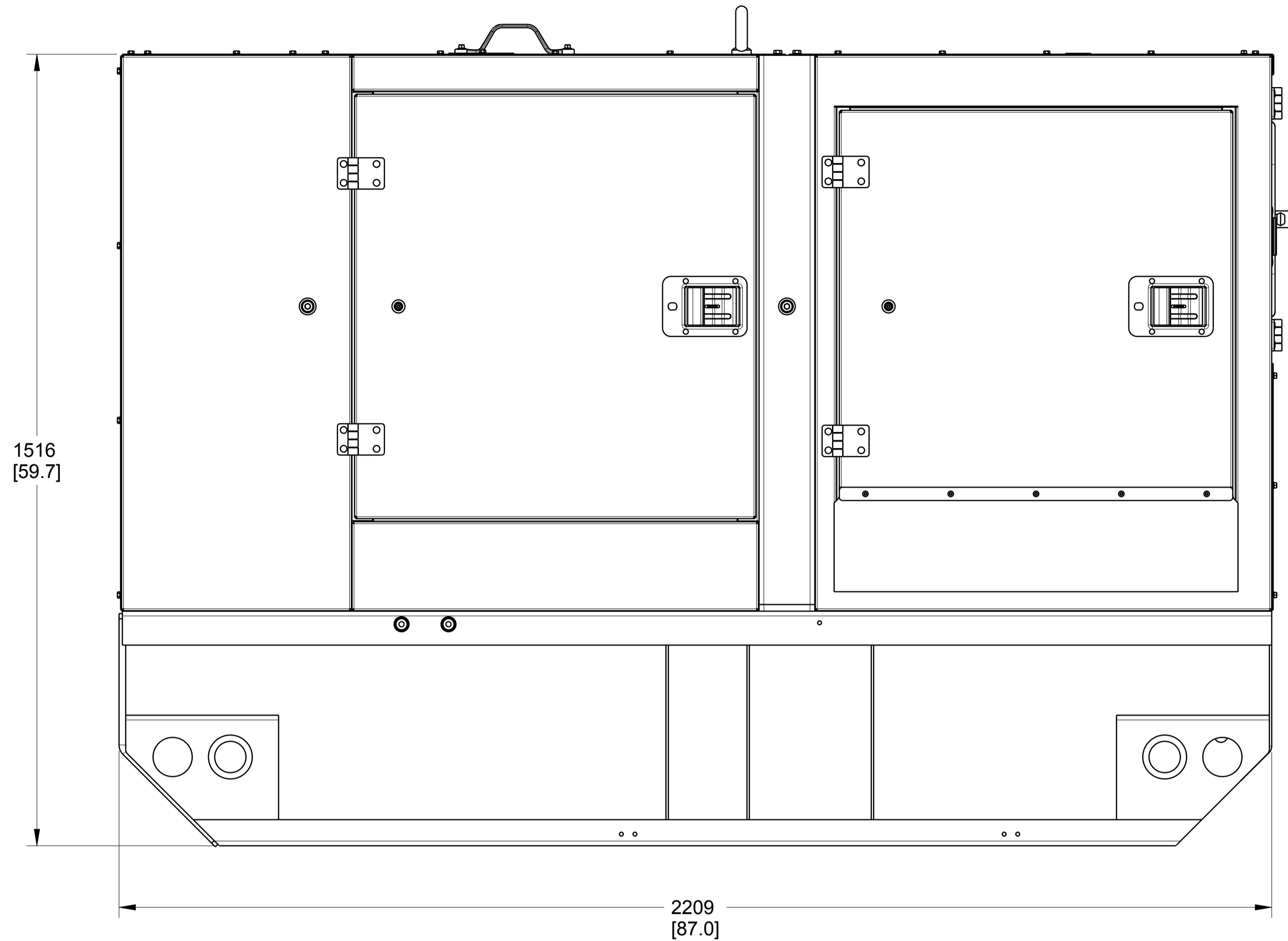

LESS RUNNING GEAR OPTION
(STREETSIDE VIEW)

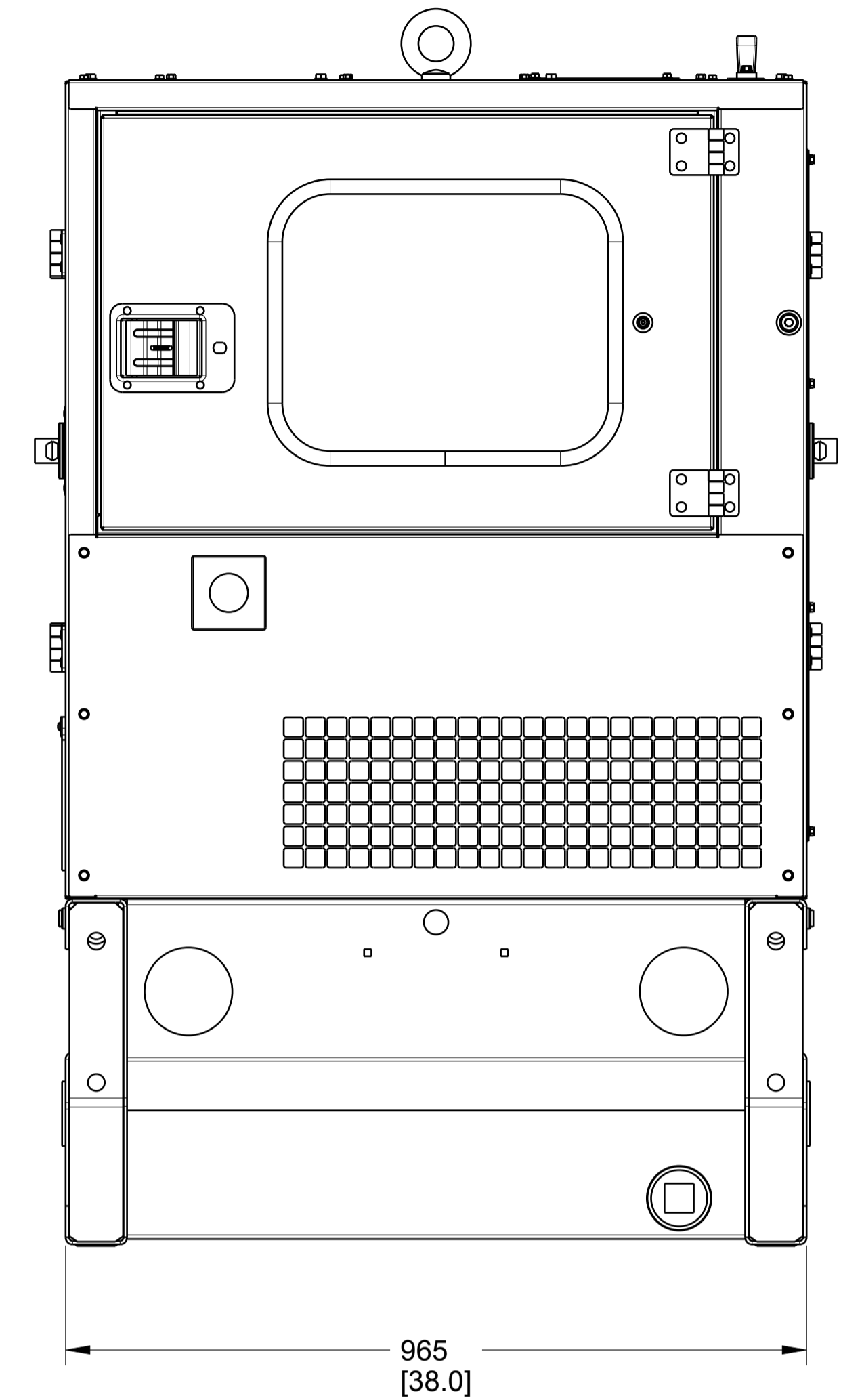

LESS RUNNING GEAR OPTION
(CONTROLS VIEW)

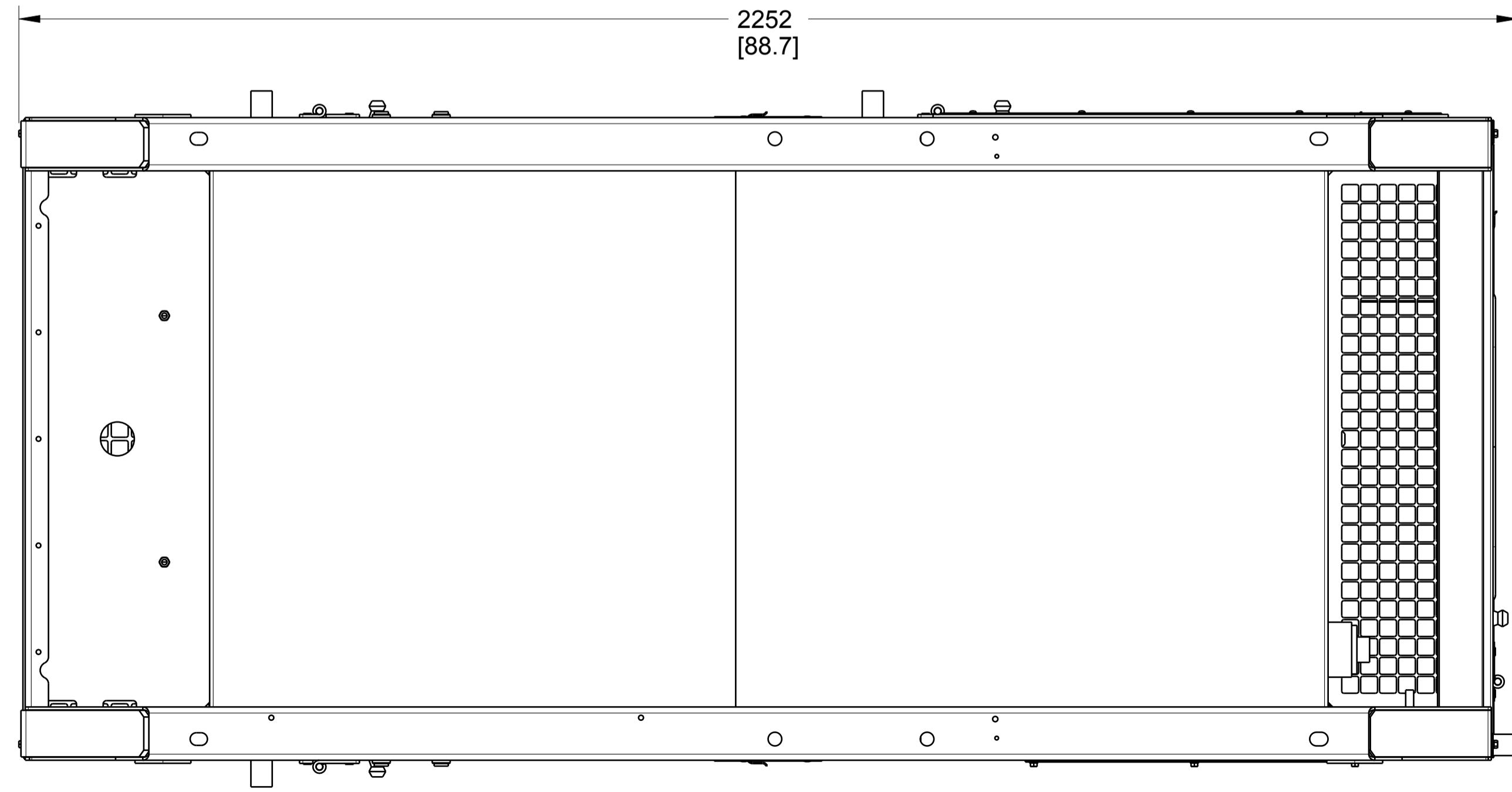

LESS RUNNING GEAR OPTION
(BOTTOM VIEW)

8 7 6 5 4 3 2 1

UNLESS OTHERWISE SPECIFIED PRINTED DOCUMENT IS UNCONTROLLED

PROPRIETARY NOTICE: THIS DRAWING CONTAINS CONFIDENTIAL AND TRADE SECRET INFORMATION, IS THE PROPERTY OF DOOSAN INFRACORE INTERNATIONAL, INC. AND IS GIVEN TO THE RECEIVER IN CONFIDENCE. THE RECEIVER BY RECEPTION AND RETENTION OF THE DRAWING ACCEPTS THE DRAWING IN CONFIDENCE AND AGREES THAT, EXCEPT AS AUTHORIZED IN WRITING BY DOOSAN INFRACORE INTERNATIONAL, INC., IT WILL (1) NOT USE THE DRAWING OR ANY COPY THEREOF OR THE CONFIDENTIAL OR TRADE SECRET INFORMATION THEREIN; (2) NOT COPY THE DRAWING; (3) NOT DISCLOSE TO OTHERS EITHER THE DRAWING OR THE CONFIDENTIAL OR TRADE SECRET INFORMATION THEREIN; AND (4) UPON COMPLETION OF THE NEED TO RETAIN THE DRAWING, OR UPON DEMAND, RETURN THE DRAWING, ALL COPIES THEREOF, AND ALL MATERIAL COPIED THEREFROM.

DOOSAN	ESTIMATED WEIGHT (KG UNLESS OTHERWISE SPECIFIED)	SCALE	SIZE	DWG NO.	REV
	N/A	N/A	A1	46671208	B
TITLE			UNIT:	SHEET 6 OF 6	
ASSY REF DWG, GENERAL ARRANGEMENT G50 T4F			G50 T4F		

DOOSAN_FORMAT.FRM
REV: H